

TecsPak® LT  
CCSB retrofit kit

# TCC-45/60 LTR

Miner TCC-45 LTR and TCC-60 LTR long travel constant contact side bearings are easy to install and designed to retrofit into your existing double roller or standard travel constant contact side bearing cages.



- ◀ Superior Truck Hunting Control
- ◀ Improved Curving Performance
- ◀ Maximum Car Body Control

*Protection. Reliability. Innovation.*



PERFECTING RAILCAR PERFORMANCE

# TCC-45/60 LTR

TECSPAK® LONG TRAVEL CONSTANT CONTACT  
SIDE BEARING RETROFIT KIT

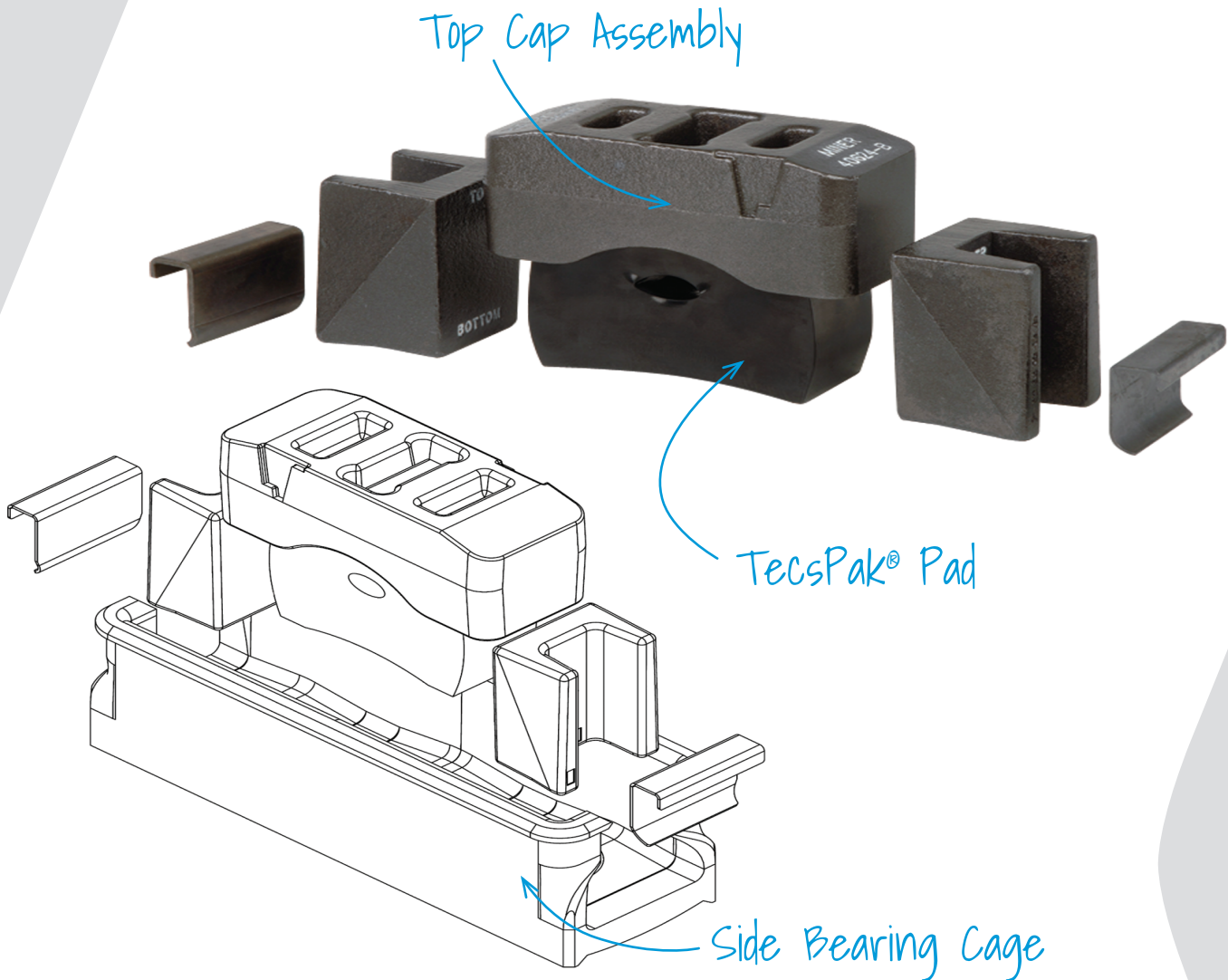

The TCC-45 LTR is designed to operate at an installed height of 5-1/16" and provide 4,500 lbs. of preload and 5/8" of travel. The TCC-60 LTR is designed to operate at an installed height of 5-1/16" and provide 6,000 lbs. of preload and 5/8" of travel.