

gravity pneumatic  
gate for food grade

# SANILOK™

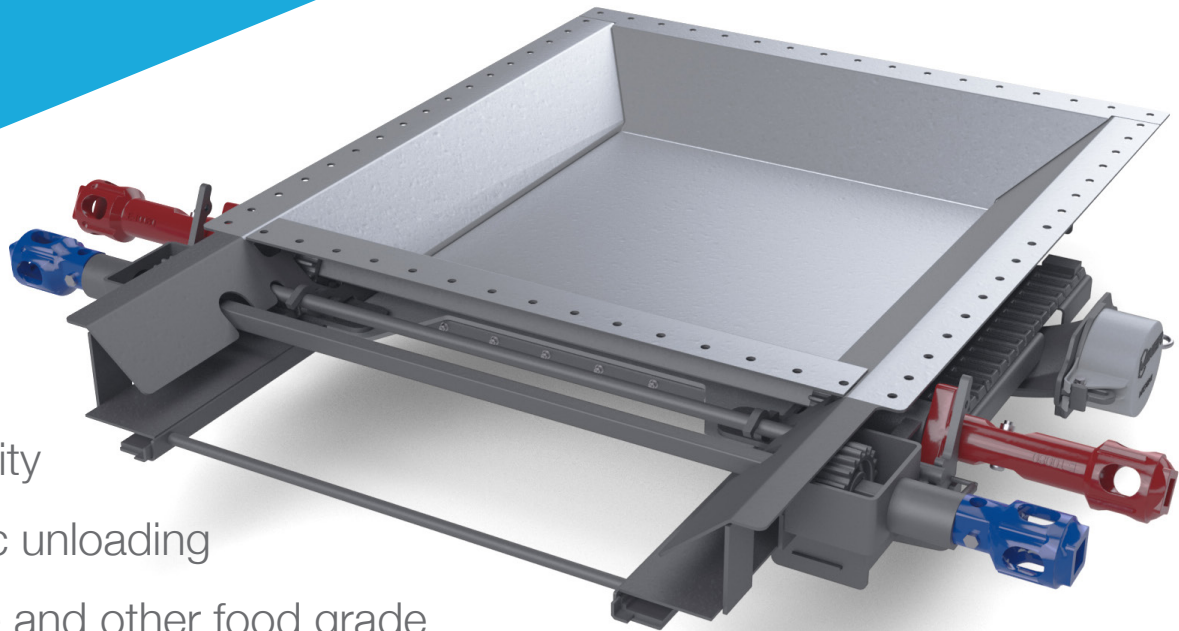

Ideal for the sanitary gravity or pneumatic unloading of sugar, rice and other food grade commodities, the SaniLOK™ is easy to clean and simple to operate. Built with all USDA and FDA approved materials in the commodity flow path, making it the sugar companies' gate of choice.

- ◀ Sanitary
- ◀ Food grade

*Simple. Reliable. Proven.*

# SANILOK™

## GRAVITY PNEUMATIC GATE FOR FOOD GRADE

### Reliable Performance

Center tube design and smooth interior surfaces ensure complete cleanout

Reliable locking operation provides maximum product security

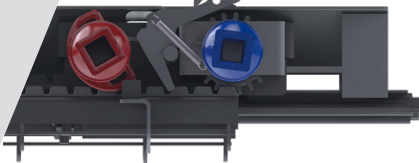

Movable plenum acts as a sanitary shield, protecting the gravity unloading boot flange

Color-coded, stationary handles allow safe operation of the gate

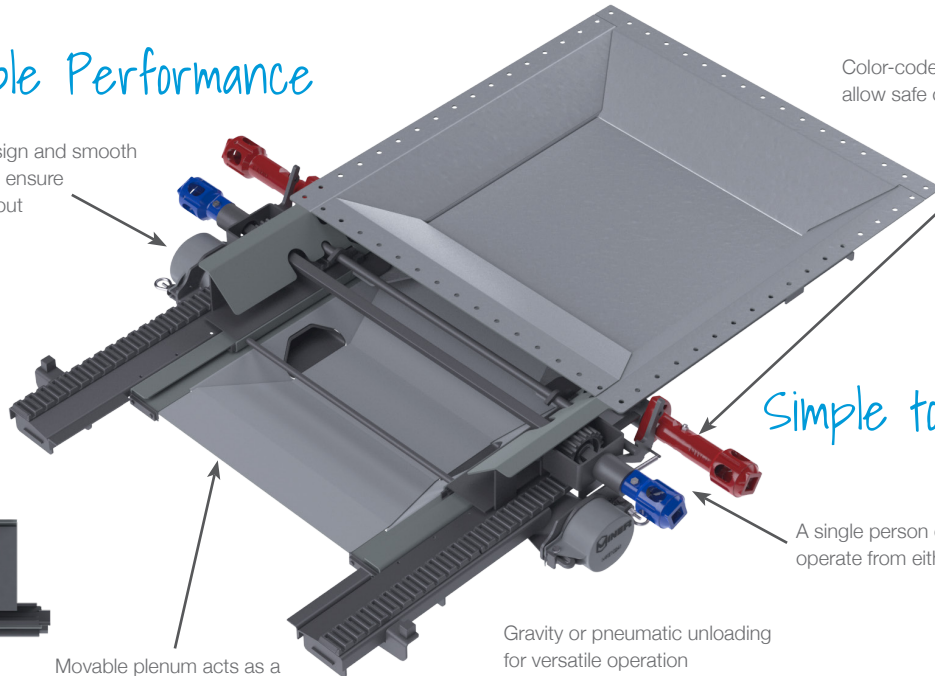

### Simple to Operate

A single person can unlock and operate from either side of the railcar

Gravity or pneumatic unloading for versatile operation

UHMW runners and low operating torque make the SaniLOK™ easy to open

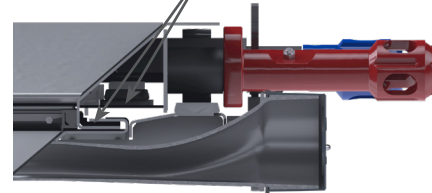

### Proven Design

Sanitary gate with only FDA materials in the flow path

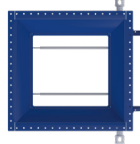
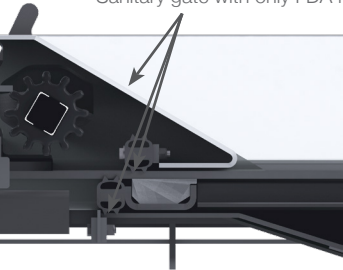

27 x 30



13 x 42

### Easy to Maintain



Easy to clean with no blind corners for commodity build up and complete access for thorough cleaning

Bolt on working points	49.88" x 47.88"	31.50" x 67.13"
Clear gate opening	27.50" x 29.63"	13.19" x 46.00"
Gravity unload flange to flange height	7.00"	7.31"
Overall gate height	11.00"	11.50"
Number of bolt holes	66	64
Weight	824 lbs	751 lbs
Typical service	Sugar / Rice / Barley / Malt / Oats / Baking Soda / Quick Lime / Bentonite Clay	