

trough hatch cover

DURASHIELD™

Light Weight. Durable. Watertight.
Miner DuraShield™ hatch covers
ensure consistent and
reliable protection in real-world
environments. Built for long service life
and minimum maintenance.

- ◀ Long Service Life
- ◀ Minimum Maintenance
- ◀ Consistent and Reliable
- ◀ Maximum Value

*Maximum Protection.
Minimum Maintenance.*

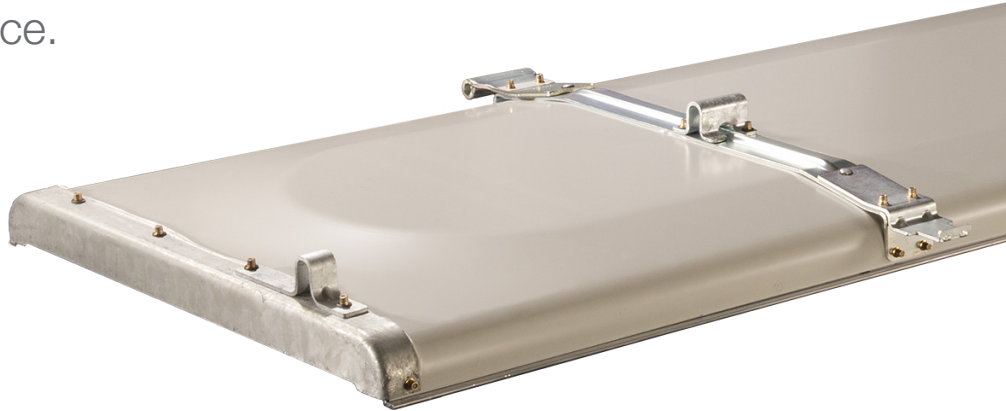

PERFECTING RAILCAR PERFORMANCE

DURASHIELD™

TROUGH HATCH COVER

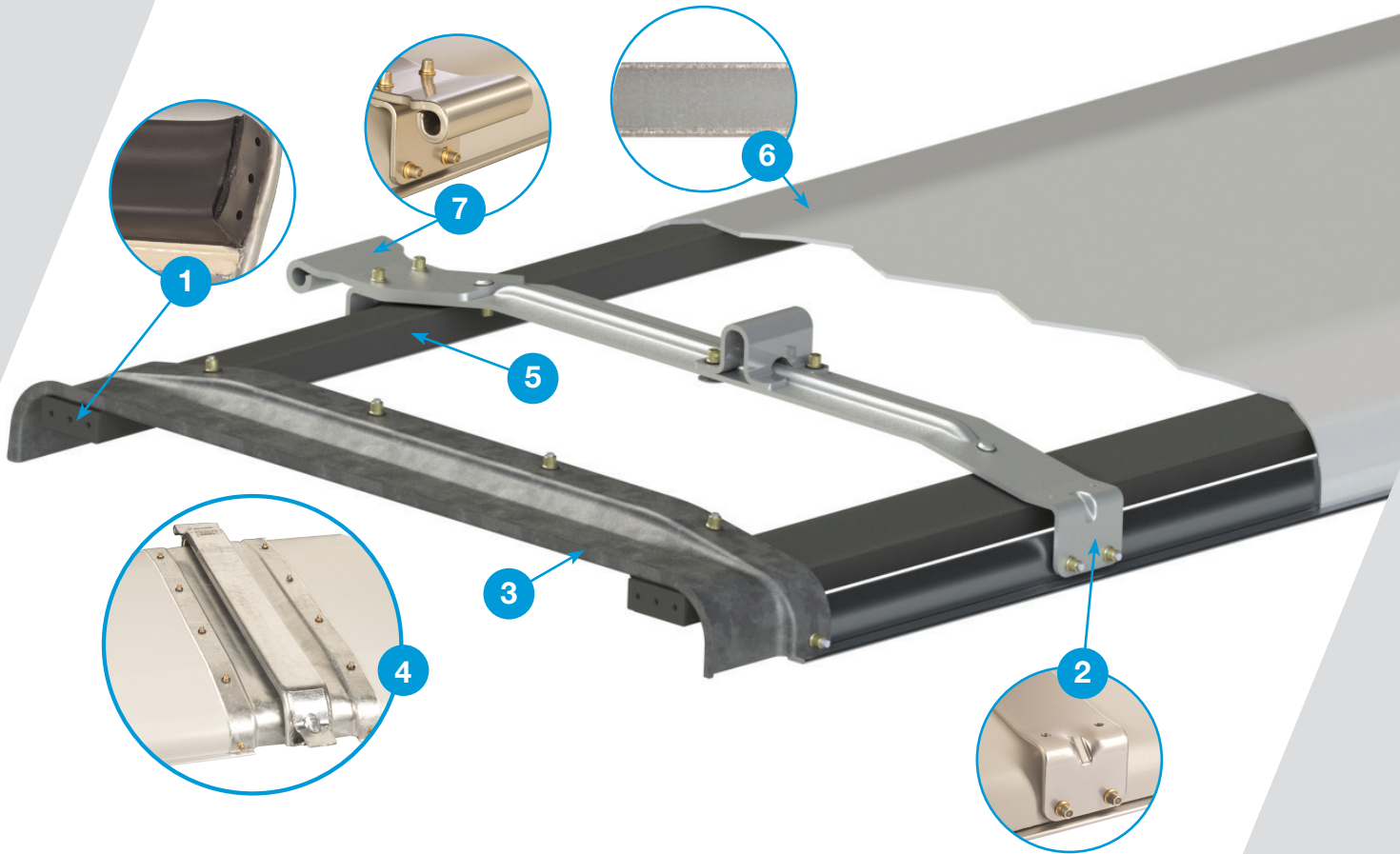

Gain These Advantages

Watertight

- 1 Continuous gasket provides a secure seal in all temperature extremes. They are 3 times stronger than the AAR specification requires.
- 2 Support straps prevent bowing and disperse stress.

Superior Protection

- 3 High strength steel cross members form the end of the frame and resist damage from batten bars.
- 4 Batten bar is made from galvanized 3/16" HSLA grade 50 steel with gussets and reinforced hinges to resist bending.

Innovative Design

- 5 Boxed frame design provides strength for greater durability and stiffness.
- 6 Aluminum composite material provides excellent strength to weight ratio.
- 7 Hinges fasten directly to the support strap to minimize cracking or leaking.