



# INSTALLATION INSTRUCTIONS MINER TCC-45 LTLP

The **Long Travel Miner TCC-45 LTLP** constant contact side bearing is designed to retrofit into an existing weld-on or cast-in "low profile" block style side bearing short pocket.

Included in each assembly are:

- TecsPak® top cap assembly
- A housing
- Two wedges

The TCC-45 LTLP is designed to operate at a set up height of 5/8" and provide 4,500 lbs. of preload and 5/8" of travel.

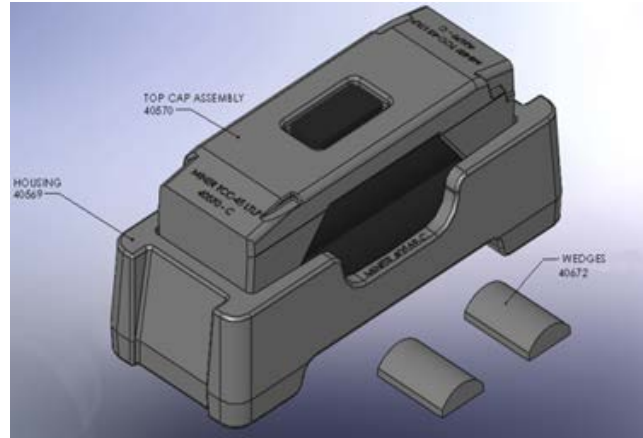

## Step 1 - Preparation

- Remove the metal block and clean the pocket of any foreign material.
- Inspect the pocket for cracks or any other damage, and repair if necessary.
- Ensure that the pocket bottom and end walls are relatively smooth and free of any weld spatter, bumps, etc.
- The car body wear plate size must be large enough based upon the Car Body Wear Plate reference table, and the car body side bearing wear plate surface must be smooth.
- Any weld spatter, heavy rust or surface projections must be removed by grinding.
- Fastener heads must be smooth and not protruding below wear plate surface, and the fasteners securely tightened.
- Plates with surface variations between fastener holes greater than 1/8", or greater than 1/16" over any 4" space between the fastener holes, must be replaced.
- Surface must be reasonably parallel to side bearing mounting surface.
- Variations should not exceed 1/16" across width or 1/8" end to end.

Car Body Wear Plate		
Truck Centers	Min. width	Min .Length
70' or Less	4"	12"
70' to 82'	4"	14"
82' to 94'	4"	16"
Greater than 94'	4"	18"

## Step 2 – Housing Securement

*The wedges are designed to install the TCC-45 LTLP into the following pocket dimensions:*

*Minimum Inside Length = 8-1/8 in.*

*Maximum Inside Length = 8-11/16 in. (Shimming is required if pocket length is greater than 8-11/16 in. See Pocket Adjustment Instructions.)*

*Minimum Inside Width = 3-1/4 in.*

*Optimal Inside Length when Shimming = 8 1/4"*

There are many different sizes of pockets that are currently in service. Pockets larger than the dimensions above may require a different model.

## Pocket Adjustment Instructions

Some pockets may be slightly larger than the TCC-45 LTLP is designed for.

Shims to be of mild, weldable steel material.

- Inside Length - If the wedges hit the pocket floor before contacting the end wall (inside length greater than 8-11/16"), shim application is required. **Optimal inside length after shimming should be 8-1/4"**. Fabricate the shim so that it is 1/4" shorter than the pocket wall and no wider than the flat portion of the end wall. Leave enough room on the shim width for welding. See Step 3 for Welding Instructions.
- Inside Width - If there is a gap greater than 1/4" along the width of the pocket, shimming is required. Estimate the shim thickness needed to reduce the pocket width to between 3 1/4" and 3 3/8". Fabricate the shim so that it is approximately 1/4" shorter than the pocket wall and no longer than the flat portion of the pocket side wall. Leave enough room on the shim length for welding. See Step 3 for Welding Instructions.
- The TCC-45 LTLP housing is 2" tall and acts as the solid stop. Therefore, the housing must extend above the pocket wall around the entire perimeter, up to a maximum of 3/8". If the pocket wall is taller than the housing, either
  - Add steel shims under the bottom of the housing covering the entire pocket floor
  - Or remove enough material from the top of wall to ensure the housing is above the pocket wall with a max of 3/8" extension.
  - Before installation and welding, check for proper space between the top of the housing and the underside of the wear plate to ensure the setup height of 5/8" can be achieved.

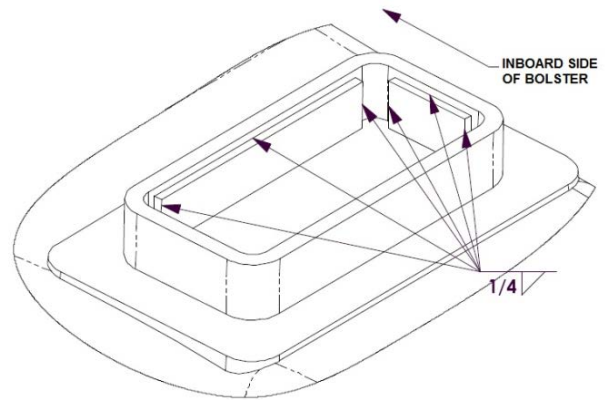

## Installation

1. Shift the housing in the pocket to the outboard side of the bolster.
2. Insert wedges in both ends.
3. Ensure that the flat side of the wedge is against the Miner housing and rounded side is against the pocket wall.
4. Ensure that all wedges do not extend beyond the housing top surface.

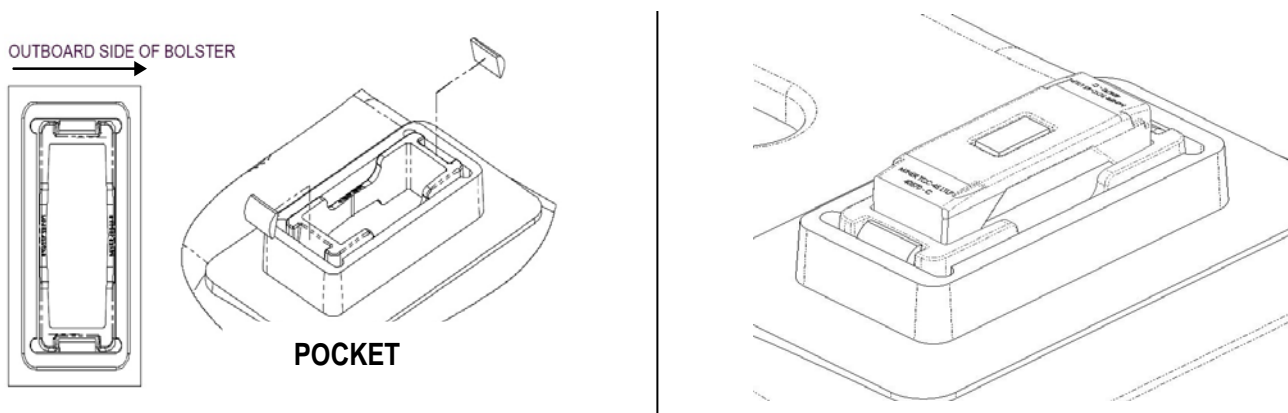

**TCC-45 LTLP Installation**

### Step 3 – Welding Instructions

All surface preparation and welding must comply with AWS D15.1 Railroad Welding Specification – Cars and Locomotives, latest edition.

1. Grind, clean and prepare for welding
2. For cast pockets, AAR M-214 recommends preheating between 300 °F and 600 °F, not exceeding 600 °F.
3. Materials
  - Type of weld: Flare bevel groove
  - Wedge: Cast Steel ASTM-A-27 Grade 65-35
  - For cast in pockets determine Grade of Steel of the bolster casting: Reference AAR Standard S-312
    - ❖ Grade B bolsters use AWS electrode E7018, or equivalent
    - ❖ Grade B+ bolsters use AWS electrode E8018, or equivalent
    - ❖ Grade C bolsters use AWS electrode E9018, or equivalent
  - For fabricated pocket, identify material and choose appropriate electrode per AWS D15.1

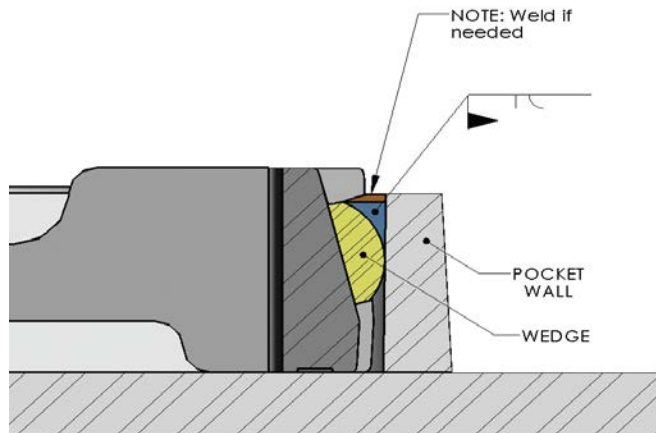

If the wedge is below the pocket wall, add reinforcement fillet weld on top. See Note above.

**DO NOT WELD DIRECTLY ON MINER HOUSING.**

### Step 4 - Set-Up Height Adjustment

1. The set-up height should be adjusted by measuring between the top corner of the housing and the underside of the car-body wear plate with an empty car positioned on level track before installing the top cap assembly or applying solid center plate lube.
2. Adjust shims as necessary to achieve 5/8" +/- 1/16".
3. With new non-metallic liner or lube disc, nominal set up is 11/16" +/- 1/16"

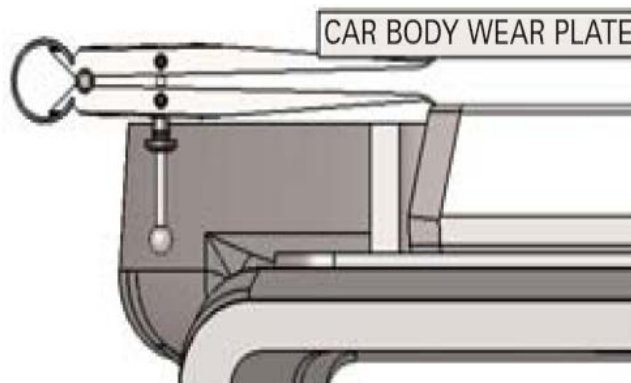

### Step 5 - Final Assembly

1. After the weld has cooled, place top cap assembly into housing and lower car.
2. The TecsPak® pad must not be exposed to temperature environments higher than 200° F, or 175° F for extended periods of time (2-3 hours).
3. After the side bearings have been installed, and the car body lowered onto the trucks, the set up height will probably be greater than the original set up.
4. Initial set needs to take place and this height will gradually reach the design set-up height.
5. The TecsPak® pads should be maintained at a 40° F or higher temperature for at least 24 hours before assembly on a car.
6. At temperatures lower than 40° F, the settling time for the setup height may require at least 24 hours.

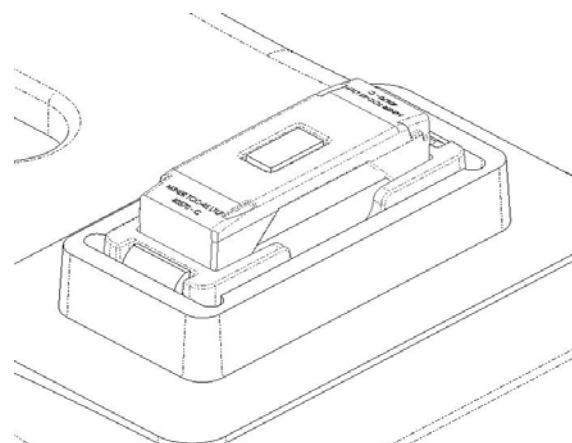

1200 East State Street  
Geneva, IL 60134  
[www.minerent.com](http://www.minerent.com)  
630-232-3000

