



©Miner Enterprises 2019



SaniLOK[®] Discharge Gate

Operating Manual

Revision D

11/13/2024



Section 1

SaniLOK® Discharge Gate

Section 1

Table of Contents

Table of Contents.....	Section 1
General Information.....	Section 2
Safety Precautions.....	Section 3
Gate Description and Operation.....	Section 4
Gate Cleaning Guidelines.....	Section 5
Gate Sealing Guidelines.....	Section 6
Maintenance and Troubleshooting.....	Section 7



SaniLOK® Discharge Gate

Section 2

General Information

This manual consists of information which will be useful in operating and maintaining your SaniLOK Discharge Gate equipped cars. It includes operating and maintenance procedures, along with illustrations to assist in identifying various components by name and part number.

It is extremely important, before proceeding with operation or maintenance of your cars, that you carefully read and understand the SAFETY PRECAUTIONS SECTION 3 of this manual.

These instructions are issued to supply acceptable methods for the operation, maintenance and troubleshooting of the SaniLOK Discharge Gate, and to supply safety information to the user, which is in addition to safety, precautions prescribed by the AAR, FRA and individual handling railroads.

It is expressly understood that issuance of these Miner instructions which were prepared in good faith and are believed to be complete and accurate, shall not be construed to mean that Miner Enterprises, Inc. assumes any liability on account of accidents to persons or property involving the SaniLOK Discharge Gate.

Miner Enterprises is not responsible for car construction or design, including modifications for gate application.



Section 3

SaniLOK® Discharge Gate

Section 3

Safety Precautions

In addition to safety precautions prescribed by the car owner, loading site, unloading site, repair shop and handling railroad, the following safety precautions must be observed whenever a SaniLOK Discharge Gate is operated and whenever any maintenance is performed on it.

- 1) All maintenance, repair, or adjustment must be made on a shop or repair track where the car will not be moved.
- 2) Protective eye and ear wear should be used when gate is operated.
- 3) Read and follow Caution Notes found on the side of the car.
- 4) After unloading, confirm that the gate is completely closed and locked.
- 5) Always report an inoperable or damaged gate to a foreman or supervisor so that it may be properly repaired or replaced.
- 6) An input torque of 2,000 ft-lbs is not to be exceeded. Doing so may result in damage to the gate as well as personal injury.

Section 4

SaniLOK® Discharge Gate

Section 4

Gate Description and Operation

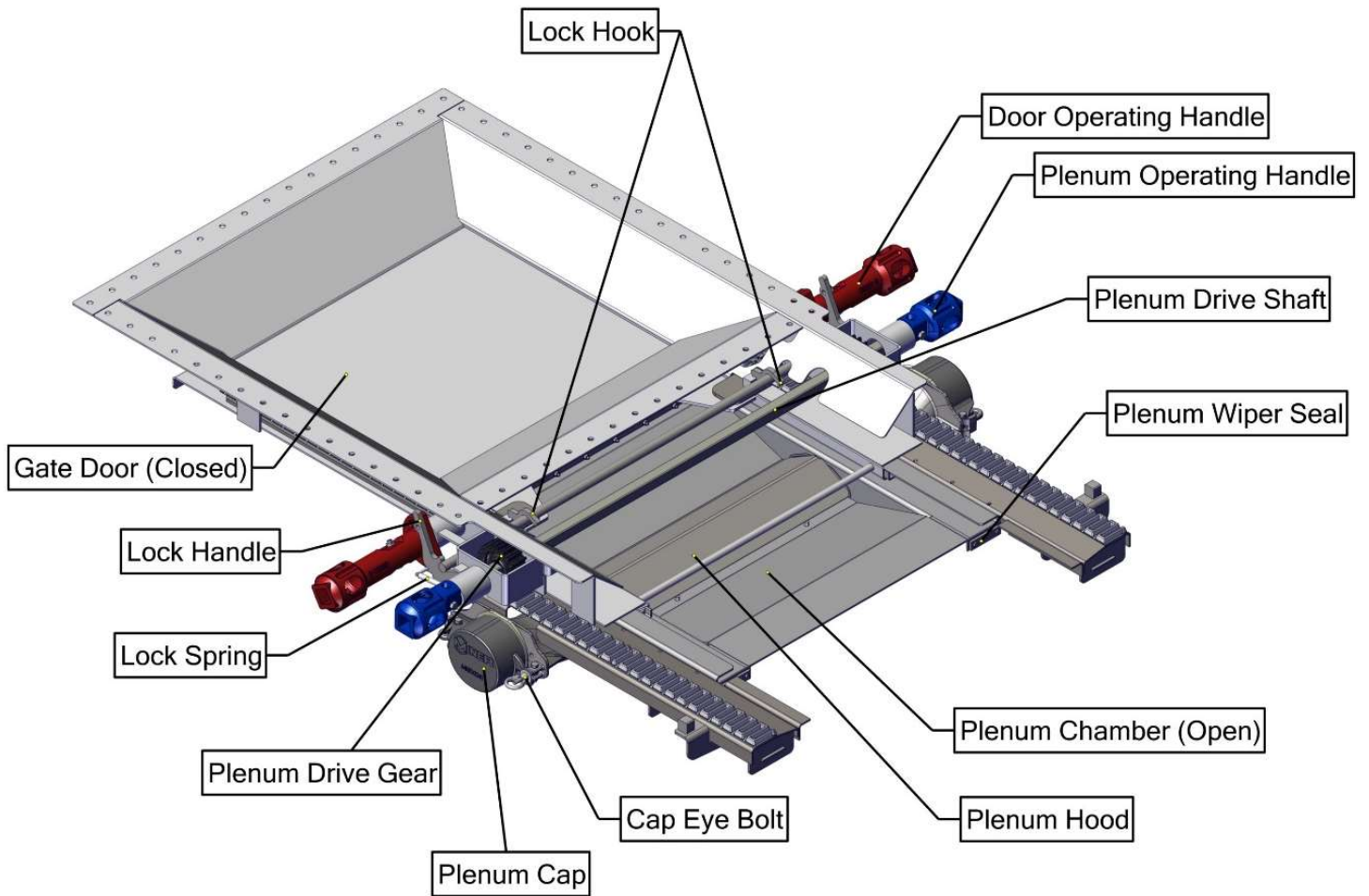

Gate Description

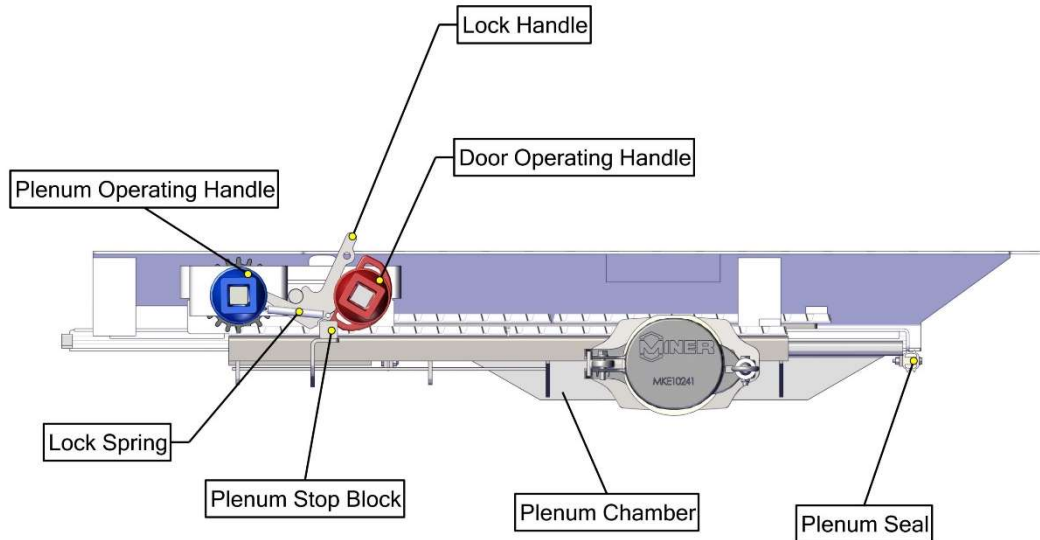

The discharge gate illustrated throughout this manual is the 27 X 30 SaniLOK. The SaniLOK is a sanitary stainless-steel gravity-pneumatic gate built with all USDA and FDA approved materials in the flow path of the commodity and has a unique movable vacuum chamber. The SaniLOK discharge gate can be operated from either side of the car. To identify your SaniLOK gate, see the identification tag on the right-hand side of the frame.

Gate Operation

Vacuum Unloading

- 1) Turn the cap eye bolts on both sides of the gate counterclockwise until sufficiently loose. Pivot the eye bolts ninety degrees in the direction away from the plenum caps.
- 2) Pivot both plenum caps to uncover the circular vacuum ports of the plenum tubes.
- 3) Attach hose(s) and connections.
- 4) Rotate the lock handle to the unlocked position as shown below to unlock the gate.
- 5) Rotate the door operating handle (Red) to open the gate door for the desired flow. (Clockwise when viewed from the right-hand side of the gate.)
- 6) Do not exceed 2000 lb-ft of torque when rotating the door operating handle or the plenum operating handle.
- 7) Vacuum unload.

Gravity Unloading

- 1) Rotate the lock handle to the open position, as shown below, to unlock the Plenum.
- 2) Turn the plenum operating (Blue) handle clockwise, when viewed from the right side of the gate, to fully open the plenum. Do not exceed 2000 lb-ft of torque when rotating the door operating handle or the plenum operating handle.
- 3) Fit unloading boot, sled, or bag if applicable.
- 4) Rotate the lock handle to the open position as shown below to unlock the slide door.
- 5) Rotate the door operating handle (Red) clockwise, when viewed from the right side of the gate, to fully open the gate door.

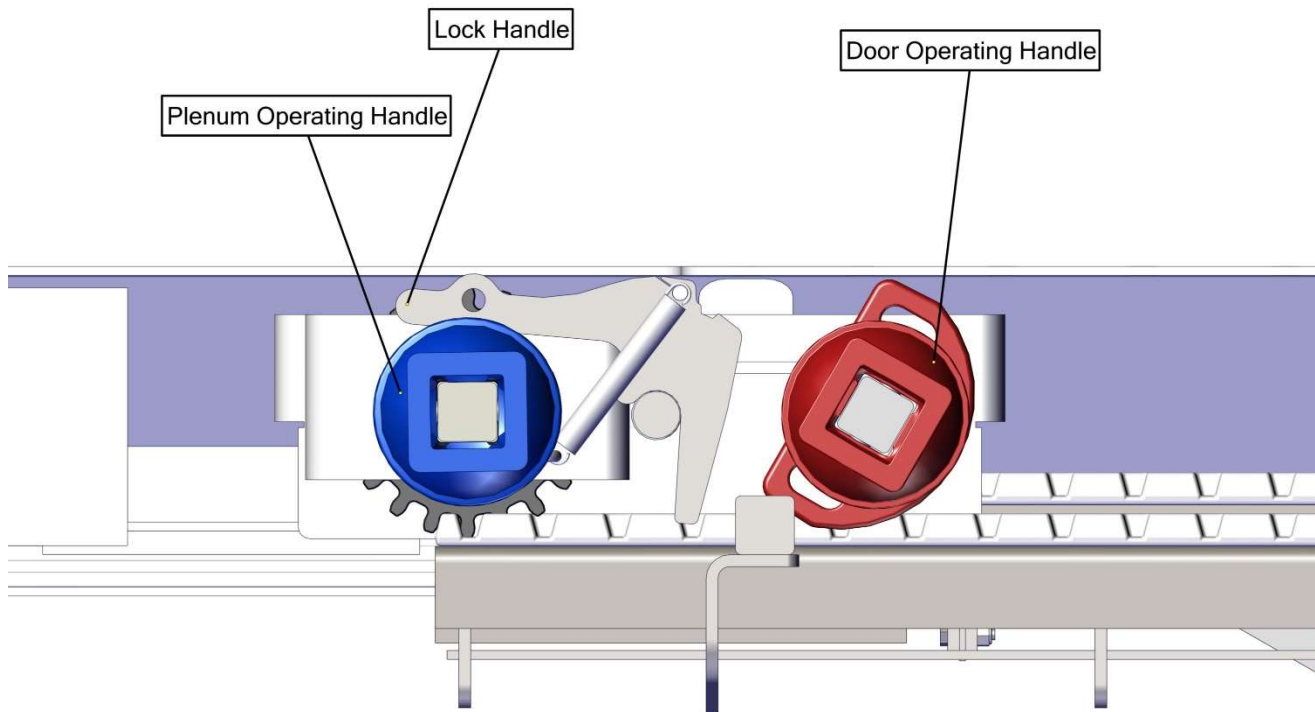

Gate Locking Procedure

- 1) Rotate the door operating handle counterclockwise when viewed from the right side to fully close the door.
- 2) Turn the plenum operating handle counterclockwise when viewed from the right side to completely close the plenum chamber. Ensure that both door and plenum chambers are fully closed.
- 3) Ensure that the lock handle has rotated to the locked position. In this position, the handle locks the slide door and the plenum shown below.

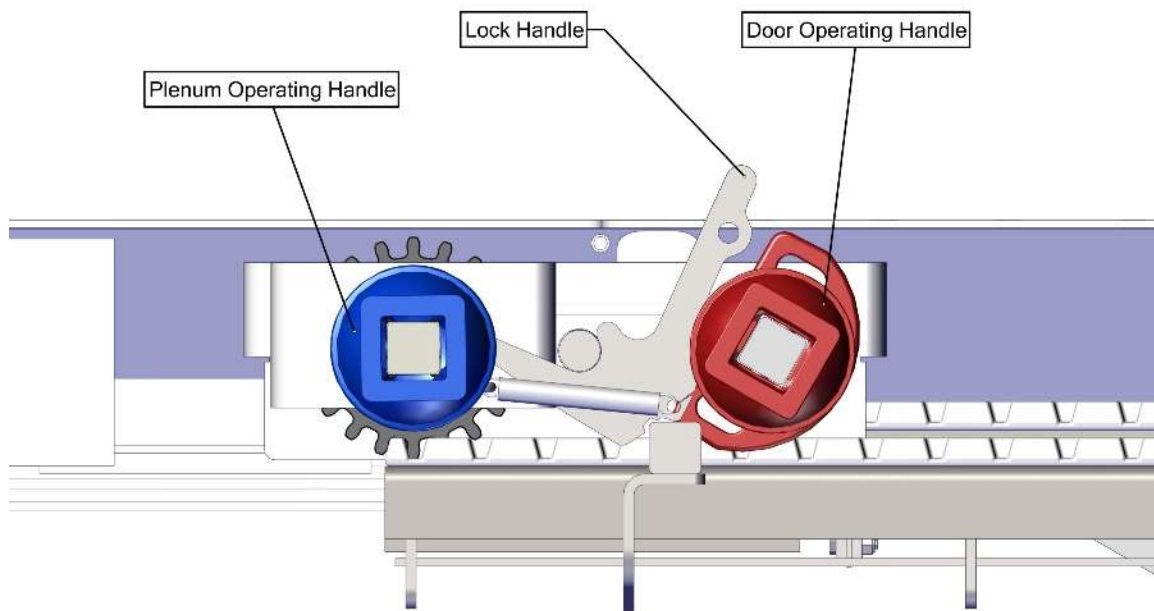

- 4) Secure and lock both plenum caps. The plenum cap eye bolts should be hand tightened until snug.



Section 5

SaniLOK® Discharge Gate

Section 5

Customer Receiving & Storage

Miner Enterprises recommends storing gates indoors in a clean and dry location prior to application on a car. Packaging provides a nominal barrier to dirt and debris; however, it is not waterproof, nor dust proof, nor immune to carrier damages. It is always recommended to clean the gates prior to applying them to the car. Failure to properly store and clean gates can result in foreign objects, dirt, debris, carbon blast, and rust or oxides to be present on gates applied to a car.

Pre-Application Cleaning

After removing the packaging material, clean the door top and slope sheets of any foreign debris. For standard dirt and debris, the cleaning method is at the discretion of the end user. Should rust or oxidation be found, the cleaning and passivation procedure found below should be performed after the rust or oxide has been mechanically removed.

Rust Removal

A majority of the components that make up the SaniLOK are made of Grade 304 Stainless Steel. Most stainless steels are susceptible to minimal surface rust if the surface gets scratched or dented. Also, the surface may show rust if it has come in contact with iron dust from grinding.

This rust is not permanent, and will not pit, flake, or bubble like the rusting of carbon steel.



Cleaning Procedure

In order to prevent rust blooms or staining, the passive layer needs to be restored. That is accomplished by the following procedure:

Materials:

- Water
- Citrisurf 77 plus
- Citrisurf 2310
- ASTM A-380 Copper Sulfate Test Kit
- Nylon bristle brush
- Blue Scotchbrite pad
- Die grinder
- 80-grit flap wheel
- Clean white cotton cloth rag

Cleaning:

1. Wash the inside of the Gate Frame Assembly
2. Scrub with Scotchbrite
3. Rinse with Citrisurf 77 Plus
4. Wipe dry
5. All oil, grease and contaminants must be removed

Grinding:

- Grind to 70 μin Ra surface profile.
- If surface has been shot blasted, all blast profile must be removed.
- This can typically be done by grinding with 80-grit to remove blast profile.
- Specific grits may vary depending on pressure and speed of grinding operation. The goal is 70 μin Ra.



Passivating

Working temperature is 50°F. As temperatures approach freezing, more time will be needed for passivation.

Apply Citrisurf 2310

1. Using a roller, apply Citrisurf to as much of the surface as possible, ensuring complete coverage with as much gel as will stick to the metal.
2. Using a paint brush, dab Citrisurf into corners and other areas not reached by the roller.
3. Allow Citrisurf to work on surface for 30 minutes.

Rinse with clean neutralized water:

1. Add sufficient lime or baking soda to water to achieve 7.0 or higher pH.
2. Thoroughly rinse all surfaces of gate assembly with water.
3. Dry completely using clean lint free towels, compressed air, or heated forced air.

Copper Sulfate Test

- Use test kit noted above.
- Test is not valid on weld seams.
- If Copper Sulfate test fails, re-passivate.



Post Application Cleaning

After application to the car, open the door and check for debris. Clean as needed.

Close the door and open the vacuum chamber. Check chamber and transition tubes for debris, rust blooms, shot blast, etc. Clean as needed. Mechanically remove rust blooms and perform the rust removal and cleaning procedures found in section 5.

General Cleaning Guidelines – In Service

- 1) The SaniLOK must be free of commodity and foreign particles so that the gate remains operable. The following items should be cleaned on a periodic basis to remove excessive commodity or foreign material that could impair the operation of the gate:
 - i. The interior UHMW door slides. The front corners of the slides tend to be the most prone to build up.
 - ii. The plenum hood and plenum hood hinges (if applicable).
 - iii. The exterior racks and pinions for the door and plenum.
 - iv. The UHMW plenum slides.
 - v. The bearings for the plenum and door operating handles.
 - vi. The lock handle springs and bearings.
 - vii. The plenum stop block and lock hooks.
 - viii. The plenum caps and cap eye bolts.

- 2) The SaniLOK cleaning method is left to the discretion of the end user. However, the method used should not:
 - i. Abrade, mar, or scratch the stainless-steel portions of the gate.
 - ii. Damage the gate and gate components in any way.

- 3) The gate should not be cleaned with any type of product that could chemically attack UHMW, Nitrile rubber, stainless steel, nylon, ABS plastic, epoxy-based paint, or acrylic based paint.

Section 6

SaniLOK® Discharge Gate

Section 6

Gate Sealing Guidelines

1. Use only approved security seals – 1/8” thick steel “air craft” cable type or better.
2. Both the plenum pan and slide door should be completely closed.
3. The lock arm should be fully locked, as shown below.
4. Place the seal through the operating handle slot and lock arm hole in the method that provides the most reliable securement. The illustration below is meant only to be conceptual in nature.
 - a. Preferred Method: The seal should be pulled tight so that the lock cannot move when sealed.

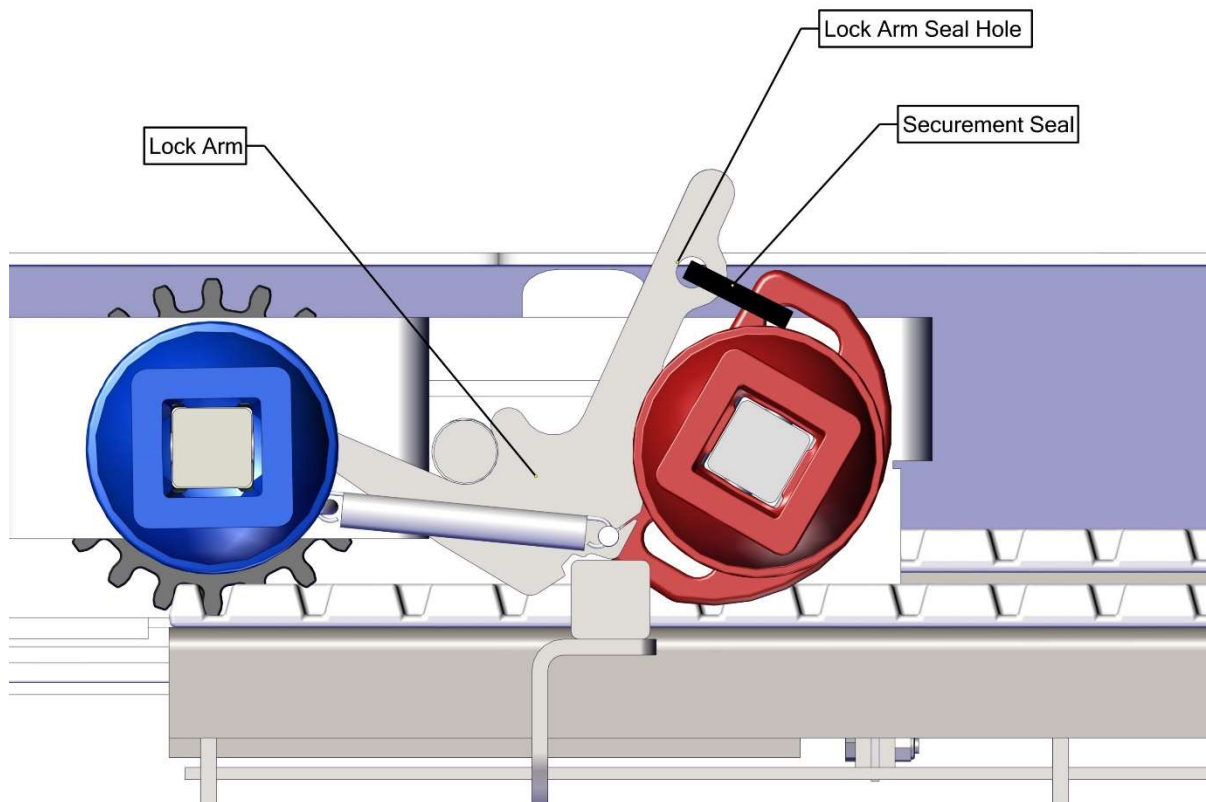

SaniLOK® Discharge Gate**Section 7****Maintenance and Troubleshooting**

Routine inspection and maintenance should be performed on the seals, lock spring, and plenum caps on a yearly basis or sooner if required. Refer to the following instructions for further details

Plenum Drive Inspection

- 1) Inspect for damaged components and foreign material. Clean per section 5.
- 2) If the plenum is still difficult to open or inoperable continue to step 3.
- 3) Unbolt a Plenum Operating Handle (Blue) from either side of the gate, remove handle. Leave the other drive handle bolted to the drive shaft.

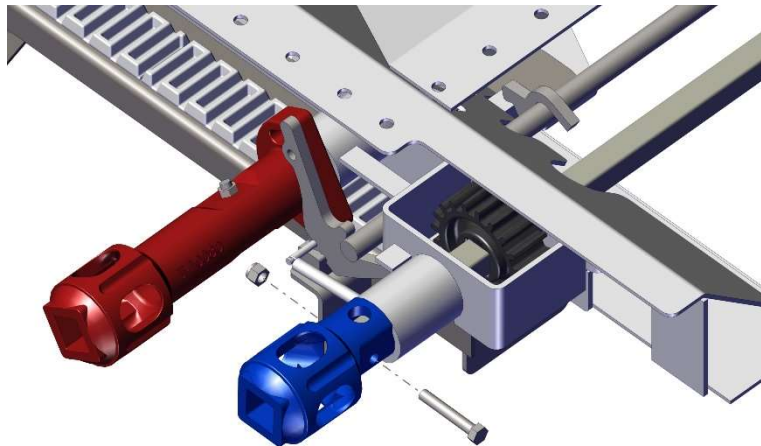

- 4) Remove the free operating handle from the drive shaft.

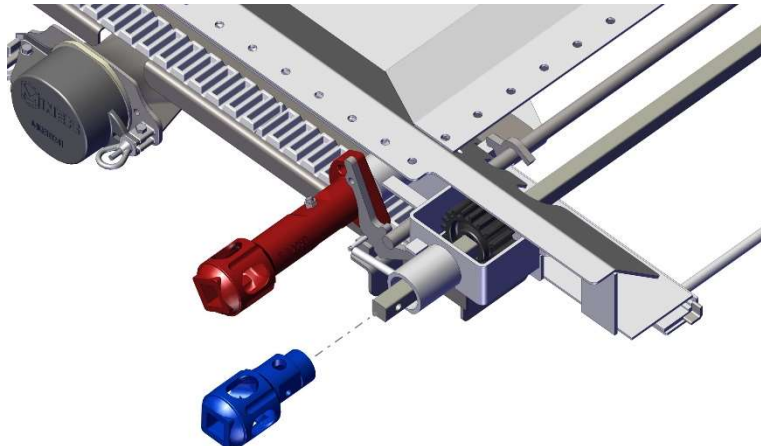

Section 7

- 5) Slide the attached handle and shaft out of the gate. The drive pinions will remain inside the bearing assembly and above the gear rack.

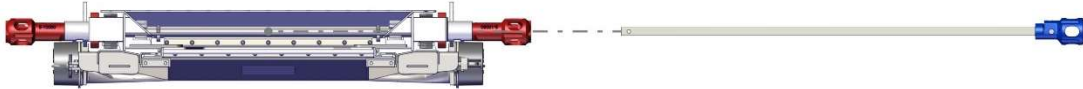

- 6) Inspect the pinions, racks, and shaft for damage.
- 7) Inspect drive shaft for angular twist, linear bow, or other signs of damage.
- 8) Do not slide the plenum chamber off of the UHMW slides that are part of the gate body. With the drive shaft and gear removed, the plenum chamber is free to slide completely off the gate. **CAUTION!** The Plenum can be completely removed, but it is heavy and should not be removed by hand!
- 9) Replace any damaged parts, using Miner supplied components.
- 10) After removing or replacing a drive handle, replace the Zinc plated bolt and elastic stop nut. Do not reuse any plastic-insert type lock nuts. Do not reuse bolt if the Zinc plating has been removed or if corrosion of the bolts has already begun. Be sure to replace the washer provided with the assembly **behind the head of the fastening bolt.**

Door Drive Inspection

- 1) Clean the door drive system, as outlined in Section 5.
- 2) If the door remains difficult to open or inoperable continue to step 3.
- 3) Unbolt a door drive handle from either side of the gate. Leave the other handle bolted to the drive shaft.
- 4) Remove the free handle from the door drive shaft.
- 5) Pull the attached handle and shaft out of the gate. Be aware that the door drive pinions may fall out of the gate.
- 6) Inspect the pinion gears for galled or broken teeth.
- 7) Inspect the drive shaft for angular twist, linear bow, or other signs of damage.
- 8) Inspect the gear racks, which are welded to the door, for broken or galled teeth. Support the end of the door as it is pulled from the end of the gate. The door is very heavy; do not remove it from the gate by hand. **Do not remove the door past the Santoprene door seals.**

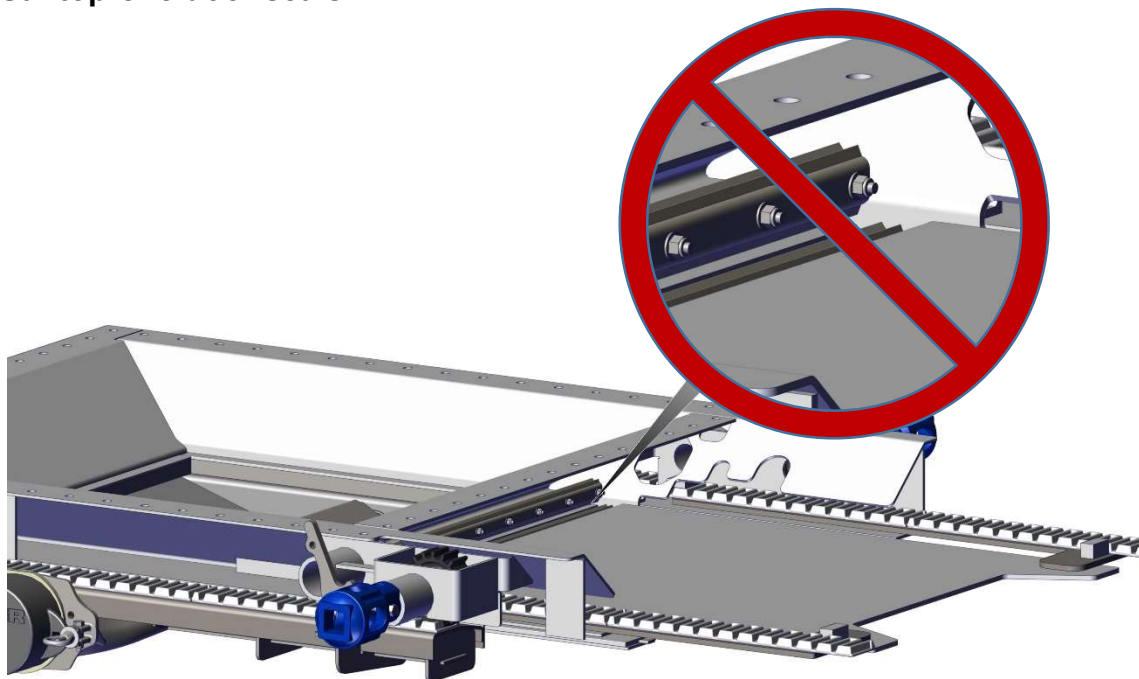

- 9) Replace the pinion gears, shafts, racks, or drive handles if they are worn in such a manner that the function of the gate is impaired. Replace any broken parts.

Re-Assembly of the Plenum and Door Drive Systems

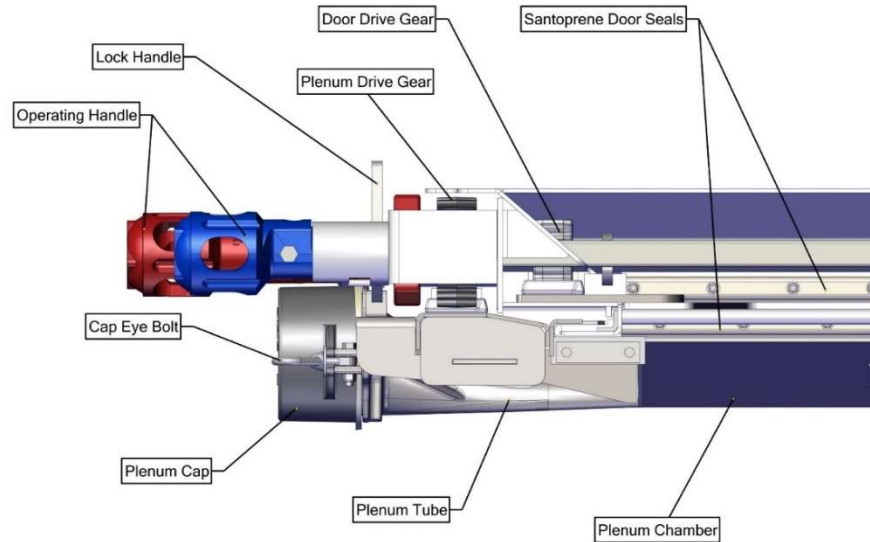

- 1) Completely close the door and the plenum chamber. Slide them back into fully closed position.
- 2) Use only functioning parts during reassembly. Replace all damaged or worn parts.
- 3) Place the plenum drive gears onto the plenum gear rack. The gears must be timed so that the square inner holes are aligned, allowing the square drive shaft to be installed. They may need to be held during shaft installation.

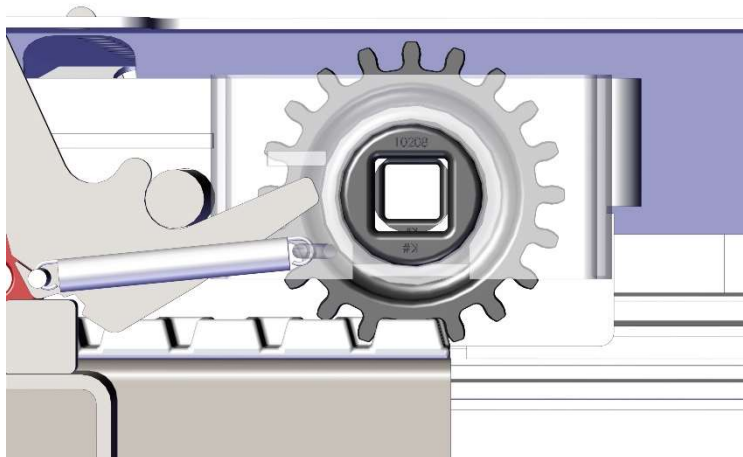

- 4) Attach one plenum drive handle to the plenum drive shaft using a new nylon lock nut. Do not reuse any plastic-insert type lock nuts. The bolt should not be reused if the Zinc plating has been removed or if corrosion of the bolt has already begun.

Section 7

- 5) Slide the plenum drive shaft assembly through the bearings on the sides of the gate. The shaft will pass through the plenum drive gear inner holes if aligned properly.
- 6) Attach the second plenum drive handle. The plenum drive handle should be attached to the shaft using a new nylon lock nut.
- 7) Place the door drive gears on the gear racks as shown below. The gears must be timed so that their square inner holes are aligned, allowing the square drive shaft to be installed. See the section on door operating handle timing for further detail.

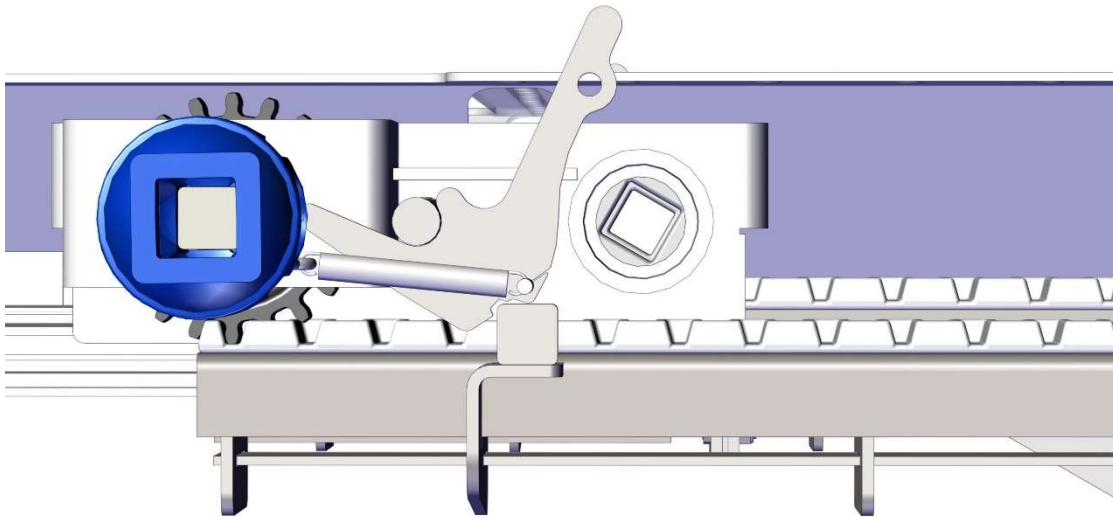

- 8) Attach one door drive handle to the door drive shaft using a new bolt and jam nut. Strike the bottom of the threads of the jam nut/bolt interface with a 3/8" punch. There should be at least two deformations of the threads of both parts at their interface to eliminate vibration loosening the jam nut.
- 9) Slide the door drive shaft assembly through the bearings on the sides of the gate. If aligned properly, the shaft will slide through the gears.

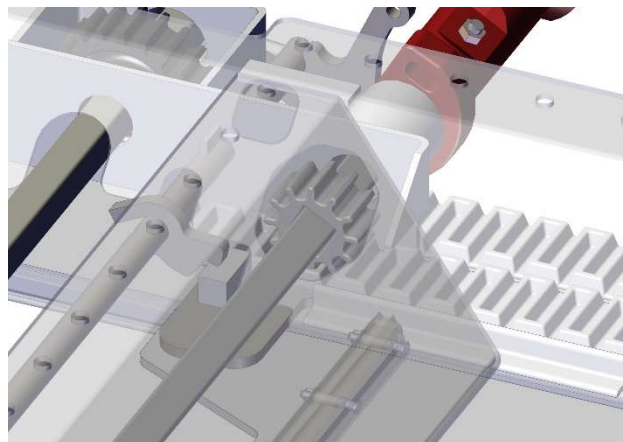

Inspecting the Plenum Seals:

- 1) Clean the debris off of the front plenum seal.

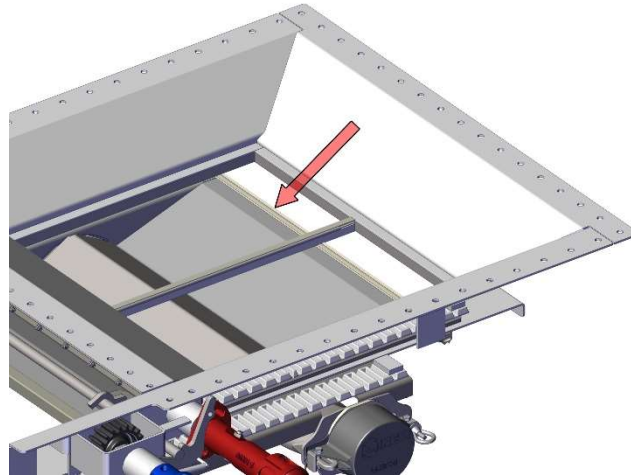

- 2) The front plenum seal should have no visible tears or missing material. Replace in kind from Miner Enterprises as needed.
- 3) Remove debris or foreign matter from the two Santoprene door seals located at the back of the gate. The seals should not have any gouges or missing material. Replace in kind from Miner Enterprises as needed.

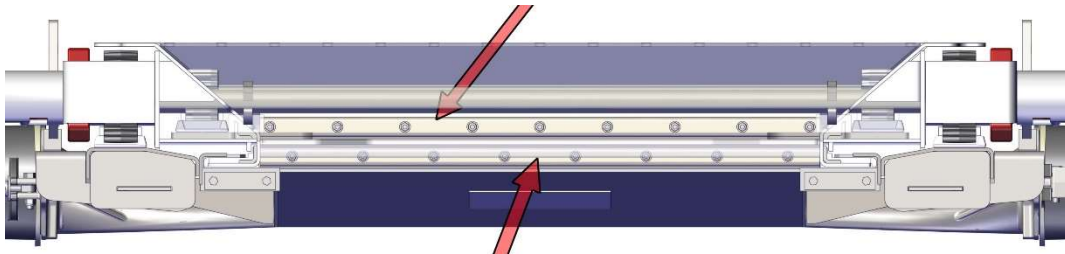

- 4) With the plenum closed, the seal should be tight to the gate frame. A credit card or similar thickness material (0.030") should not easily pass through this interface.

Inspecting the Plenum Wiper Seals

- 1) Clean debris off of the plenum wiper seal. The wiper seal is outlined in red below.

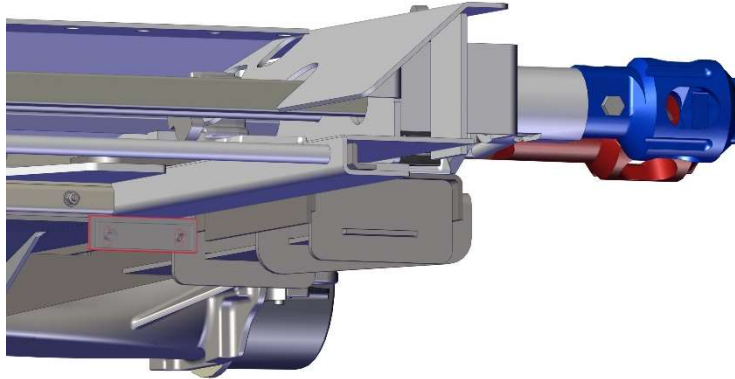

- 2) The wiper seal should completely contact the bottom of the gate frame when the plenum is fully closed.
- 3) If the seal does not contact the bottom of the gate, loosen the locating bolts and adjust the seal upward. The slots in seal will allow for proper adjustment.
- 4) If the seal is damaged, worn, or not slotted, contact Miner for replacement seals.

Door Handle Timing

- 1) The door drive handle must be properly timed to the gate for proper application of the security seal.
- 2) The figure below shows the proper orientation of the handle when viewed from the right side of the gate.
- 3) The flat plane of the activation cam should form a 60-degree angle with the gate mounting flange.

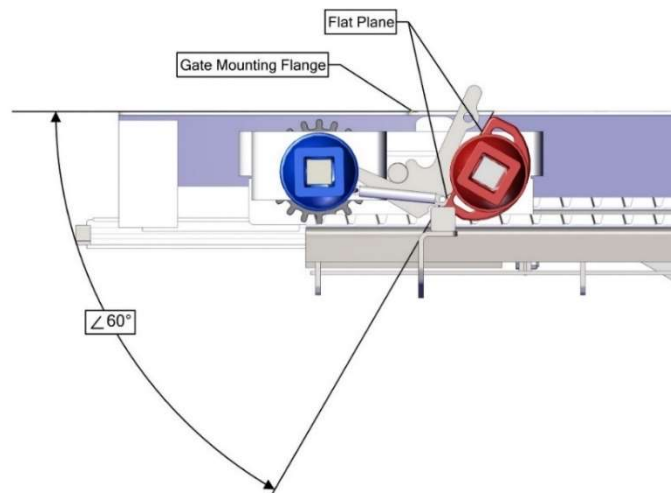

Inspecting the Door

- 1) Remove debris from the door and leading edge of the door.
- 2) The door leading edge should be smooth and free of burrs or roughness.
- 3) The door surface should be free of any deep scratches or indentations.
- 4) If possible, do not remove the door from the gate.
- 5) If the door is removed, it must be carefully inserted back into the gate.
 - i. Use food grade oil to lubricate the door seals before inserting the door.
 - ii. Hold the door parallel to the gate before putting it back into the gate.
 - iii. The force required to insert the door into the gate may be too high for a single person to perform this task. The door must deflect both top and bottom seals. The deflection of the seals accounts for the majority of the insertion force.

Replacing Lock Spring

1. The lock spring should be free of significant corrosion and in tension for all lock handle positions
2. Contact Miner Enterprises Sales to order the proper replacement spring.
3. The loops of the spring should be placed through the mounting post hole on the lock handle and through the mounting loop welded to the bearing bracket on the gate.

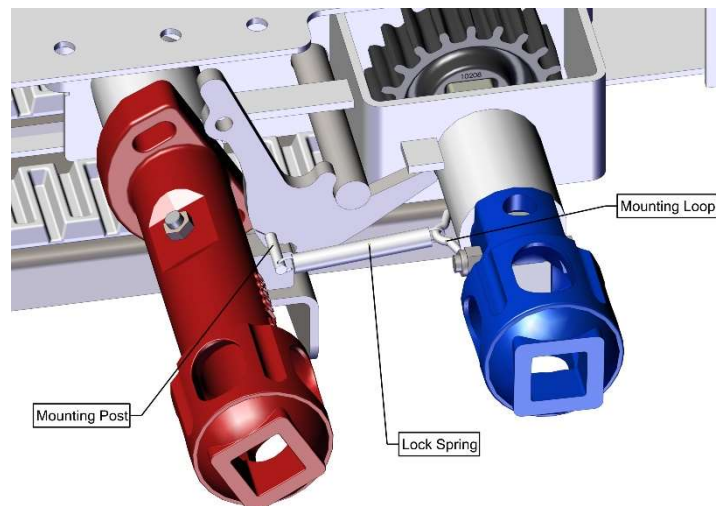

4. Crimp the loops to ensure that the spring is in tension when the arm is located in the "Closed" position.



Inspecting the Plenum Tube Cap

- 1) The Plenum Cap should be:
 - i. Physically intact, with no visible through cracks or holes.
 - ii. Colored similar to its original medium grey color. Significant color changes could indicate material weakness or failure.
 - iii. Stainless steel caps should be replaced in kind.
- 2) Contact Miner Enterprises to order the proper plenum cap replacement.

CAUTION

1. DO NOT strike or use heat on outlet gate or door to force open.
2. Use of powered gate opening units to force doors open may damage outlet gate.
3. Use of other mechanical devices (Car pullers, come-a-longs, hydraulic jacks) to open units may damage outlet gate.
4. Use recommended operating procedures specified in this manual.

NEED HELP?

For further assistance or information, contact Miner at 630-232-3000.
Please have your gate model number handy.