

ITEM	QTY	PART NUMBER	DESCRIPTION	DRAWING NUMBER
1	1	MKE10575	FRAME ASSEMBLY	M-169-42
2	1	MKE10558	DOOR ASSEMBLY	M-169-11
3	1	MKE10562	OPERATING SHAFT	25481
4	2	MKE10080	OPERATION HANDLE WITH ACTIVATION CAM	M-85-12
5	2	MKE10129	SLIP PINION, SYMMETRIC	M-85-53
6	2	P30000615	1/2 - 20 LCKNUT ZN	P30000615
7	2	P30000611	1/2-20 X3 HHCS ZN	P30000611
8	2	MKE10263	CARPET SEAL	M-85-21
9	2	MKE10561	CARPET SEAL	M-85-21
10	3	P10260003	DOOR SUPPORT RUNNER	M-85-39

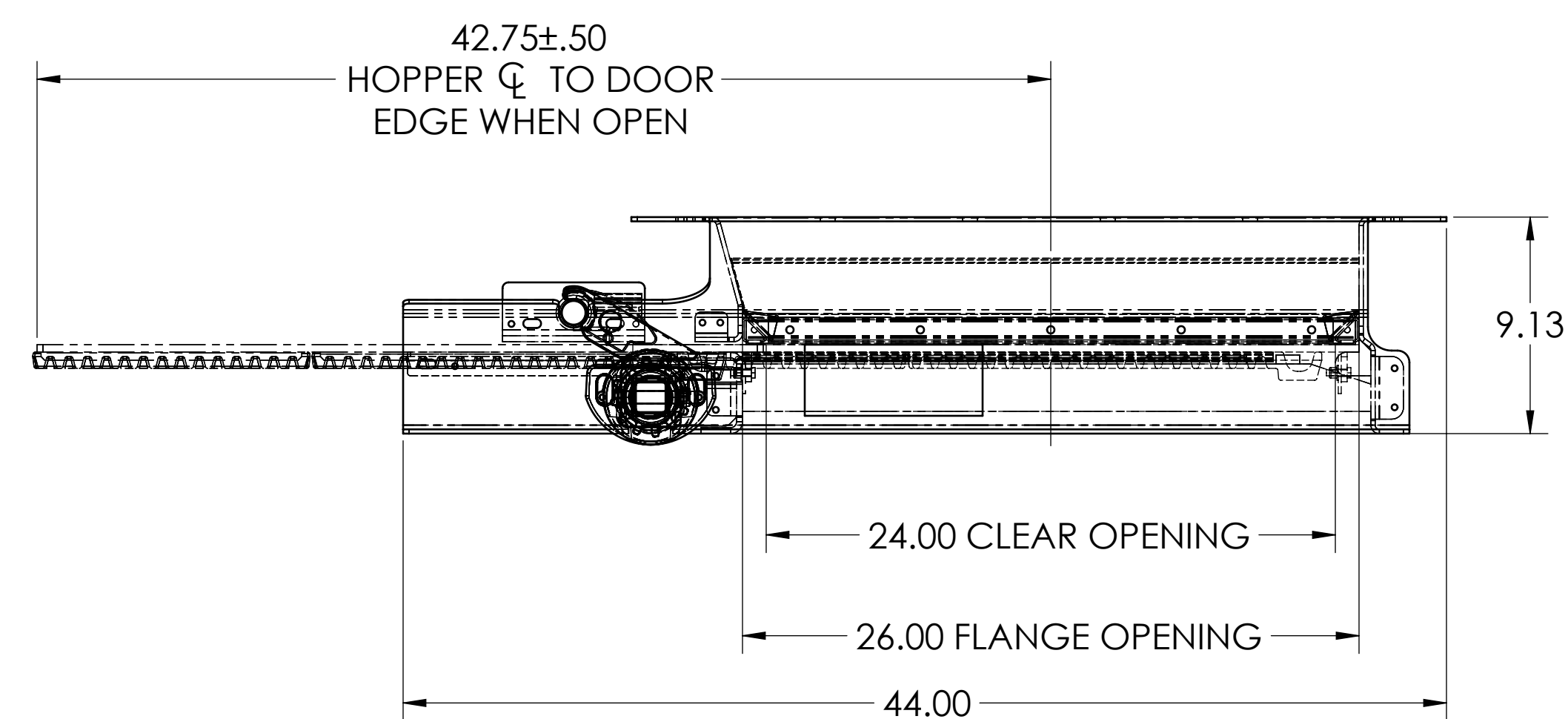
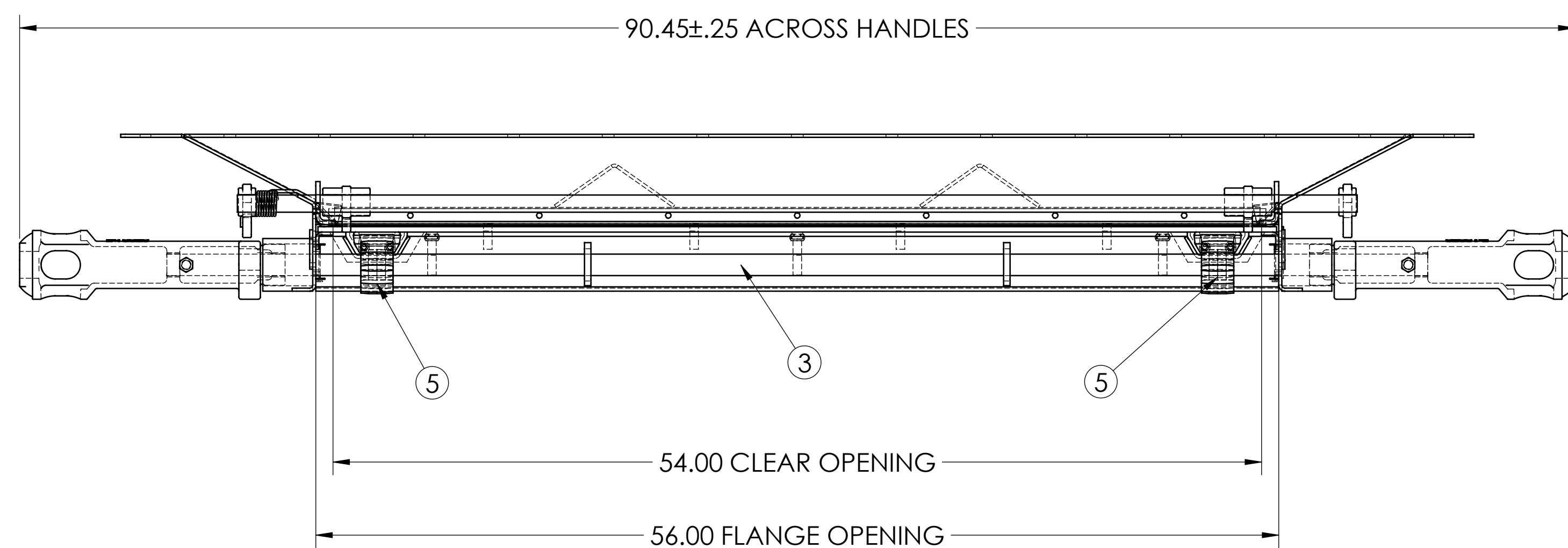
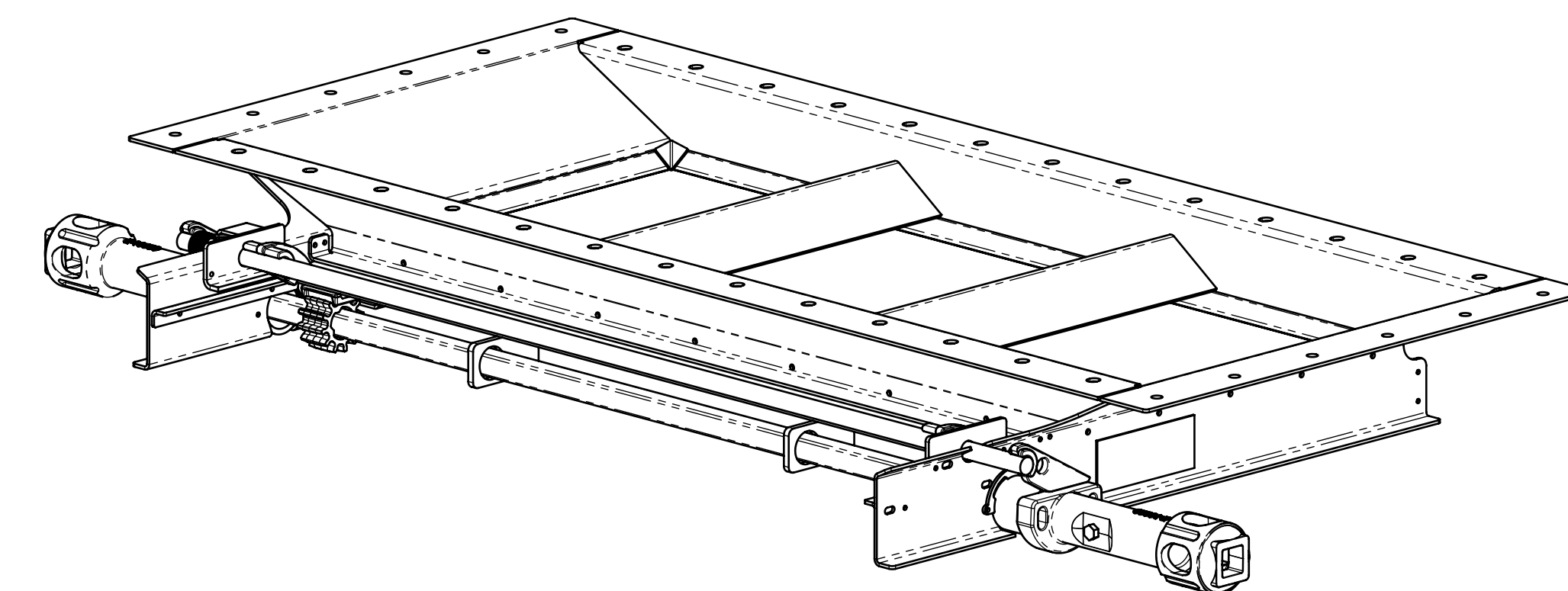

THIS DRAWING IS THE PROPERTY OF MINER ENTERPRISES INC. WHO CLAIMS PROPRIETARY RIGHTS IN THE MATERIAL DISCLOSED. IT IS ISSUED IN CONFIDENCE FOR ENGINEERING INFORMATION ONLY AND MAY NOT BE COPIED OR USED FOR MANUFACTURE OF ANYTHING SHOWN WITHOUT SPECIFIC WRITTEN PERMISSION FROM MINER ENTERPRISES INC. COPYRIGHT MINER ENTERPRISES, INC. 2007.

DIMENSIONAL TOLERANCES			
ALL DIMENSIONS IN INCHES UNLESS OTHERWISE SPECIFIED			
UNLESS OTHERWISE SPECIFIED:		TOLERANCES ARE NOT ACCUMULATIVE	
2 PL. DEC:	±0.06		
3 PL. DEC:	±0.031		
ANGLES:	±1°		
		MILLIMETERS: ±0.13	
 W. H. MINER DIVISION			
1200 EAST STATE STREET		GENEVA, IL 60134	
TITLE 24 X 54 AutoLOK II GATE ARRANGEMENT 38 HOLE-PLASTIC PELLET HOLE PATTERN			
PART:	MKE10574	MATERIAL:	SEE LIST
WEIGHT:	523.26		
DEVICE:	24 X 54 AutoLOK II		
REFERENCE:			
SCALE:	1:6		
DR BY:	RMC	DATE:	9/30/09
DR BY:	BS	DATE:	
PART/CAT NO:	MKE10574	DRAWING NO:	M-169-41
REV:			