



©Miner Enterprises 2019



AutoLOK™ I Discharge Gate

AutoLOK I Manual

Revision A

1/3/2020



Section 1

AutoLOK™ I Discharge Gate

Section 1

Table of Contents

Table of Contents.....	Section 1
General Information.....	Section 2
Safety Precautions.....	Section 3
Gate Description and Operation.....	Section 4
Maintenance.....	Section 5
Trouble Shooting.....	Section 6



AutoLOK™ I Discharge Gate

Section 2

General Information

This manual consists of information which will be useful in operating and maintaining your AutoLOK I Discharge Gate equipped cars. It includes operating and maintenance procedures, along with illustrations to assist in identifying various components by name and part number.

It is extremely important, before proceeding with operation or maintenance of your cars, that you carefully read and understand the SAFETY PRECAUTIONS SECTION 3 of this manual.

These instructions are issued to supply acceptable methods for the operation, maintenance and troubleshooting of the AutoLOK I Discharge Gate, and to supply safety information to the user, which is in addition to safety, precautions prescribed by the AAR, FRA and individual handling railroads.

It is expressly understood that issuance of these Miner instructions which were prepared in good faith and are believed to be complete and accurate, shall not be construed to mean that Miner Enterprises, Inc. assumes any liability on account of accidents to persons or property involving the AutoLOK I Discharge Gate.

Miner Enterprises is not responsible for car construction or design, including modifications for gate application.



Section 3

AutoLOK™ I Discharge Gate

Section 3

Safety Precautions

In addition to safety precautions prescribed by the car owner, loading site, unloading site, repair shop and handling railroad, the following safety precautions must be observed whenever an AutoLOK I Discharge Gate is operated and whenever any maintenance is performed on it.

- 1) All maintenance, repair, or adjustment must be made on a shop or repair track where the car will not be moved.
- 2) Protective eye and ear wear should be used when gate is operated.
- 3) Read and follow Caution Notes found on the side of the car.
- 4) After unloading, confirm that the gate is completely closed and locked.
- 5) Always report an inoperable or damaged gate to a foreman or supervisor so that it may be properly repaired or replaced.
- 6) An input torque of 1,800 ft-lbs is not to be exceeded. Doing so may result in damage to the gate as well as personal injury.

AutoLOK™ I Discharge Gate

Section 4

Gate Description and Operation

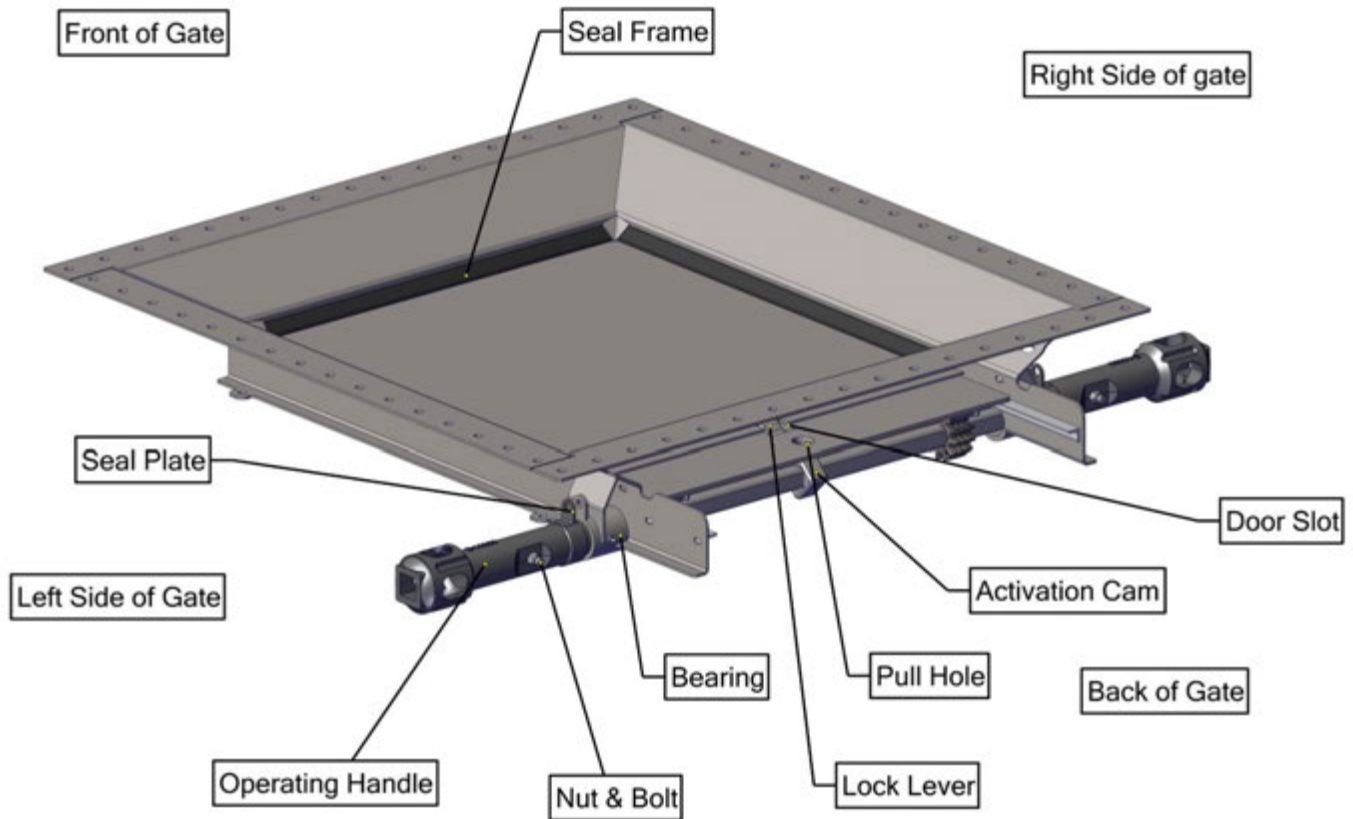

Gate Description:

The 30x30 AutoLOK™ I Discharge Gate shown above is in the closed and locked position. The AutoLOK™ I is equipped with “Lost Motion” technology allowing the gate to automatically lock and unlock the gate. The AutoLOK™ I is also equipped with carpet seals, which offer durability and maximum leak protection. The capstan on the operating handle offers a 1-1/2” square opening for powered/automatic openers.

Lock System:

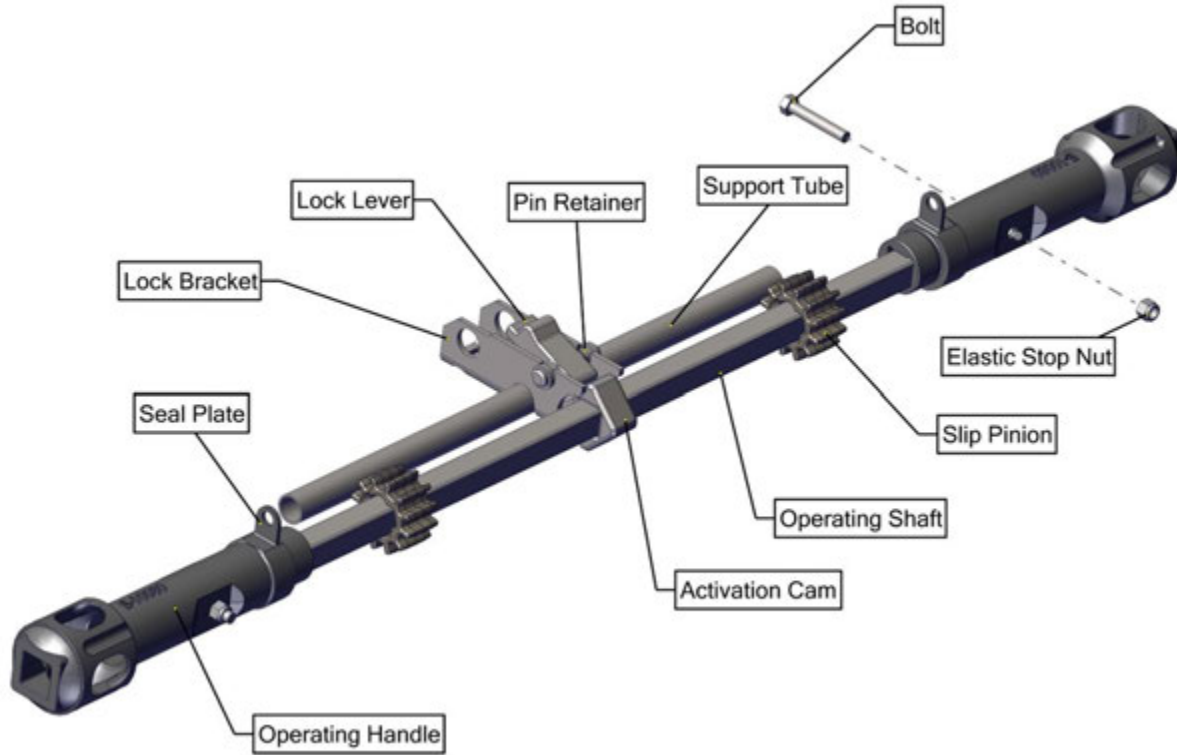

Gate Operation:

Manual Operation:

1. Insert a bar into the gate handle. Using downward pressure, rotate the handle in the direction shown to unlock the gate.
2. Continue rotating the handle to open the gate. Reposition the bar as needed.
(Caution: To prevent injury, assume a stable position and apply downward pressure using body weight).

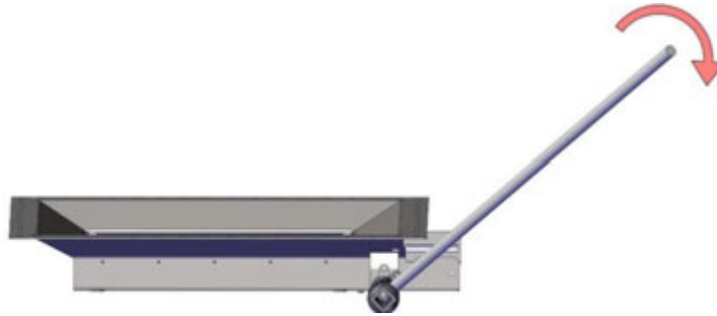

3. Position the door to adjust the flow of commodity as needed.
4. To close the gate, again insert the bar into the gate handle and rotate the handle in the direction shown.

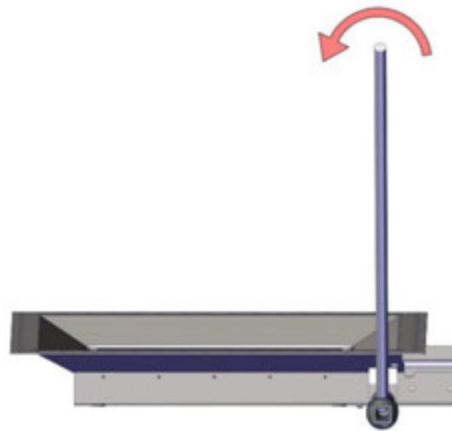

5. The seal plates will align, and the lock lever will protrude through the door cutout as the door shuts, locking the door.

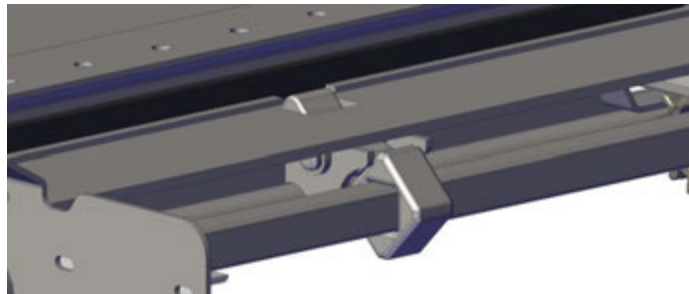

Powered Operation:

1. To open, insert a 1 ½" male square drive into the operating handle. If using a tapered drive tool, ensure the tool is completely inserted into the handle before operating the gate. Rotate in the direction shown.

(Caution: Do not continuously apply torque to gate when it is completely open. Damage may occur to the entire gate).

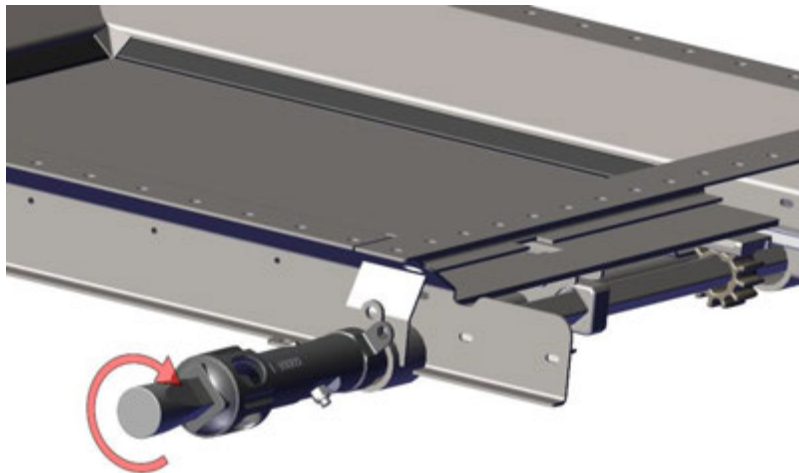

2. Position the door and adjust the flow of commodity as needed,
3. To close the door, insert a 1-1/2" male square drive into the operating handle. Rotate in the direction shown.

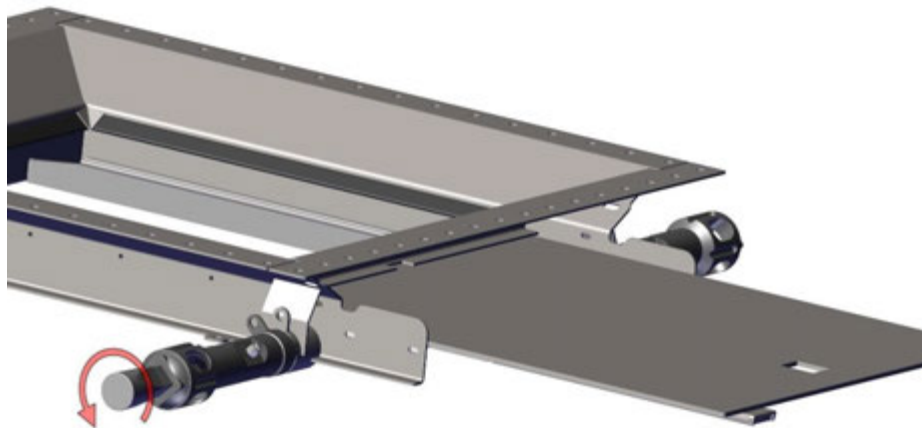

4. The seal plates will align, and the lock lever will protrude through the door cutout as the door shuts, locking the door.

AutoLOK™ I Discharge Gate

Section 5 Maintenance

Inspecting the Drive System

1. Unbolt one of the handles and remove it from the operating shaft as shown below. (DO NOT torch cut)

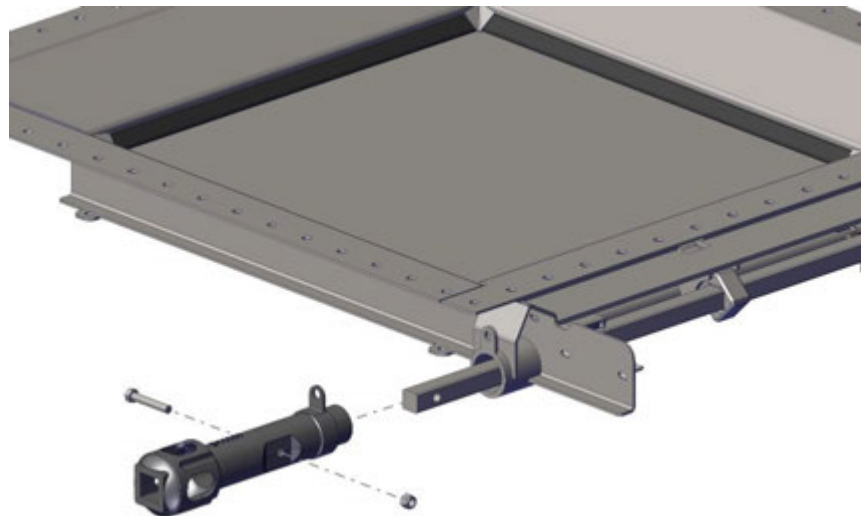

2. Pull the remaining handle and shaft out of the unit. The slip pinions and activation cam will fall.



3. Inspect all removed parts for wear and breakage. If any parts need to be replaced, contact Miner Sales for the correct replacement.

Slip Pinion Timing

1. Slide the operating shaft with the handle mounted through one bearing and let the shaft hang down.

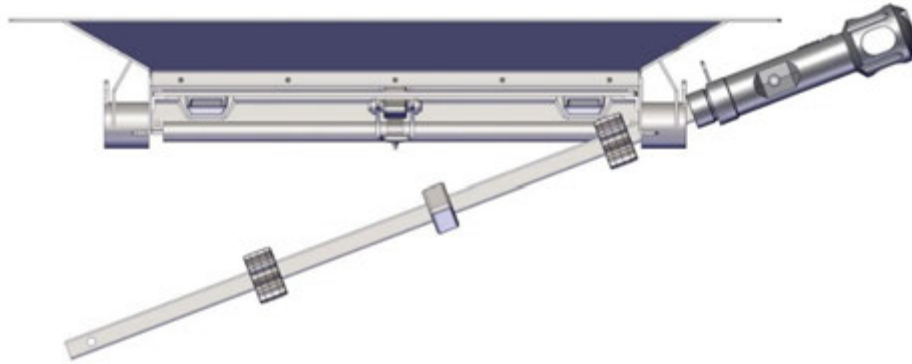

2. Slide both the slip pinions and the activation cam onto the shaft.
3. Align the pinions as shown below and pivot the shaft up to rest on the bearings.
4. Note that the handle tabs and seal plates should be aligned, and the top of the shaft is flat.
5. Lift the shaft so that the pinions engage with the racks, and the activation cam is centered in the lock bracket.

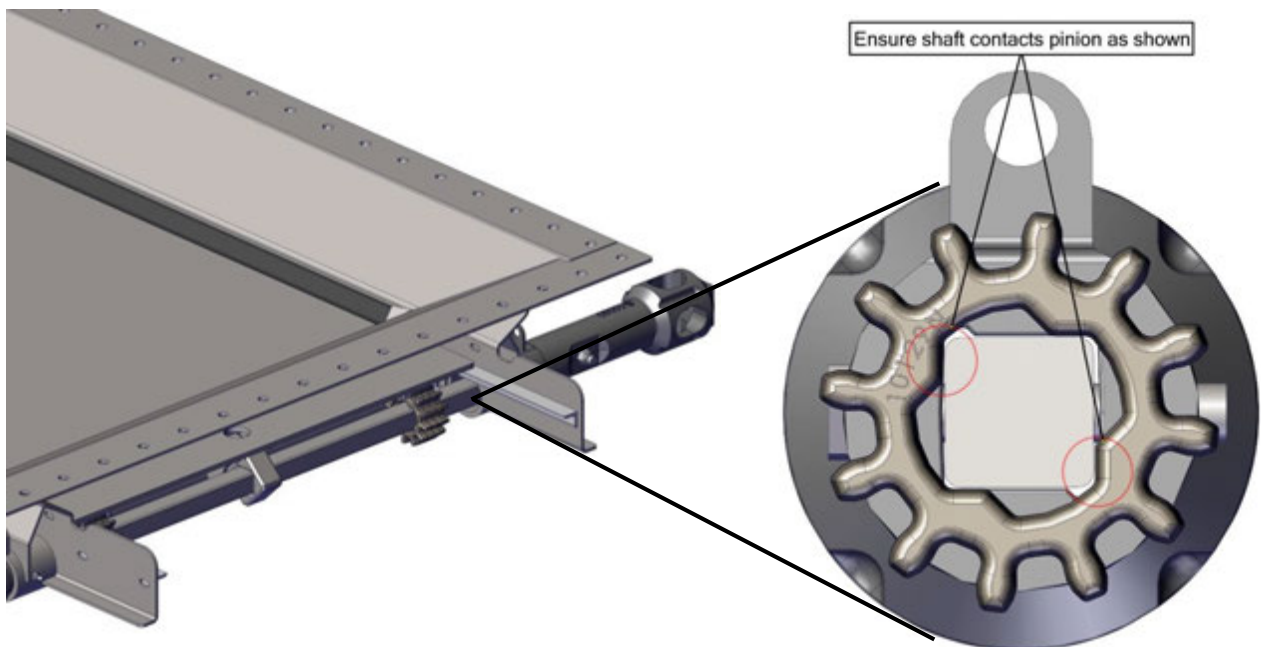

6. Attach the other handle to the operating shaft with an elastic stop nut and bolt.
7. Rotate handle to verify lock operation.
8. If lock operates incorrectly, remove one handle and repeat steps 2 through 6.

Lock Spring Maintenance

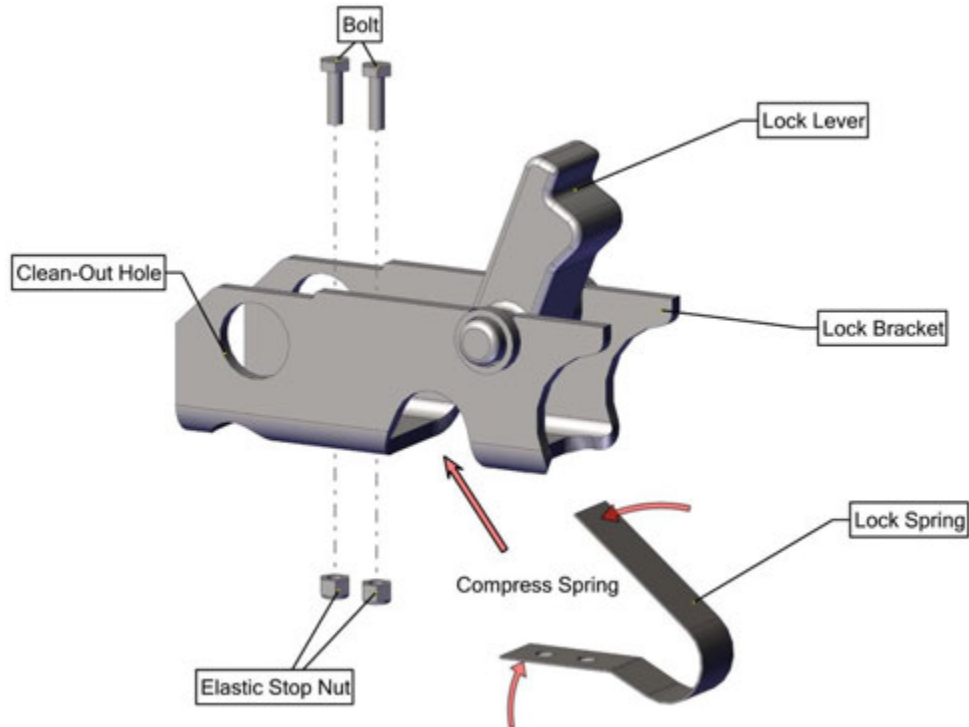

The lock spring requires maintenance when it is determined that the lock lever no longer snaps into the door slot. Check to see if debris is interfering with the lock spring. If there is debris in the lock bracket, rinse it out with water and recheck lock function. If the gate will still not lock, the lock spring should be replaced.

1. Remove the shaft assembly as shown.
2. Carefully remove the door from the frame. (*Caution: The door is very heavy. Do not attempt to remove the door alone.*)
3. The lock lever should then be rotated to expose the spring as shown above.
4. Remove the elastic stop nuts and bolts.
5. Rotate the spring and slide it out of the lock bracket.
6. Compress the new spring and insert it into the lock bracket.
7. Using new elastic stop nuts, reinsert the nuts and bolts and tighten them to secure the lock spring.
8. Rotate the lock lever to rest on the spring.
9. Reinsert the door and shaft assembly back into the frame of the gate.
10. Check the function of the locking mechanism.

Seal Maintenance

The 30x30 Miner AutoLOK I outlet gate is a sealed gate using carpet seals on all four sides. The 13x42 Miner AutoLOK I outlet gate has 3 carpet seals and one neoprene seal. Follow this guide for assistance in inspecting and maintaining the carpet seals on your AutoLOK I outlet gate.

To Inspect AutoLOK I Seals:

The door should open and close while locking freely with a two-foot-long bar.

Run hand along bottom of seal frame: The carpet should feel flat from $\frac{3}{4}$ " to 1" wide around seal frame bottom perimeter. You should **Not** feel a rounded rod below the seal frame slot level.

The door closing should compress carpet. Seals should be free of tears, heat damage, paint, and excessive commodity build-up.

To Inspect Individual Seals for Wear:

If any heat damage, excessive commodity build-up, paint, tears or pile wrap separations (gaps) greater than $\frac{1}{4}$ " appear, replace seals. Contact Miner Customer Service for replacement seals.

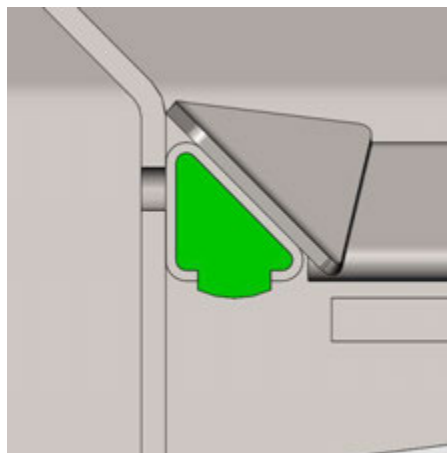

Removal of the Seals

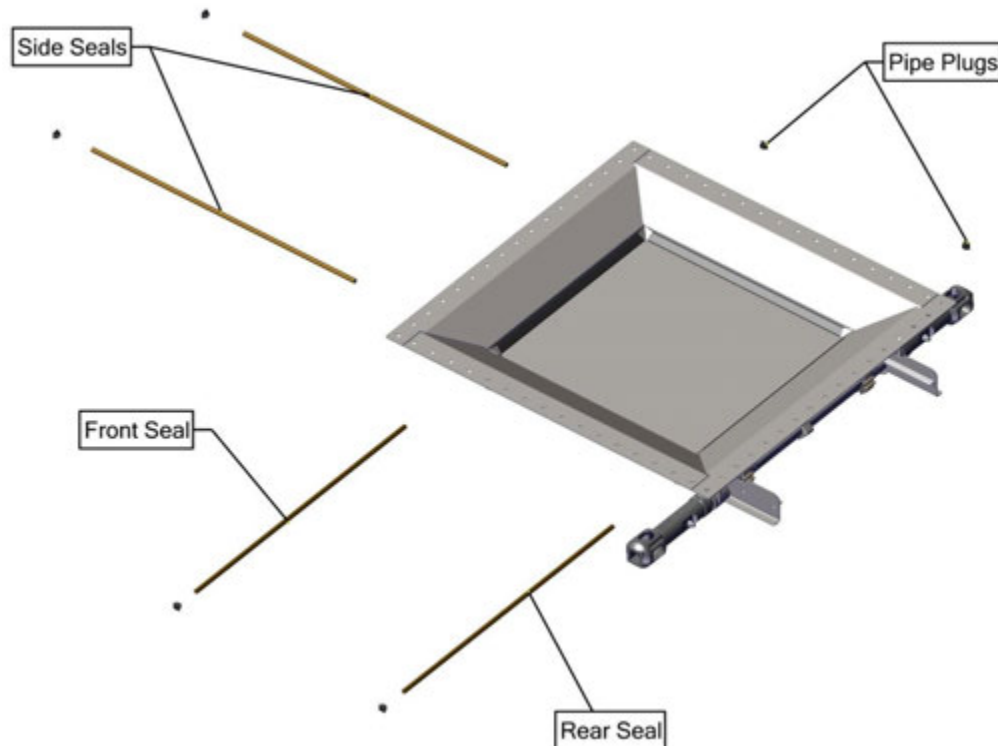

1. Remove all six pipe plugs.
2. Remove one of the side seals by inserting a needle nose pliers into the seal frame. Pull the carpet seal out.
3. If the seal sticks, open the gate completely and use a flat head screwdriver to pry the seal towards the gate front.
4. Repeat for the other side seal.
5. Remove the front seal by using a hammer and punch to push the carpet seal out of the seal frame. Pliers can be used to assist in removal from the other side of the gate.
6. Repeat for the rear seal.
7. It is not recommended to reuse carpet seals as they may have been bent during removal. Please contact Miner Customer Service for replacement seals.

Inserting Seals:

Before inserting seals, inspect them and ensure that they are in good condition. A carpet seal in good condition is shown in Figure 1 below. A Neoprene seal in good condition is shown in Figure 2 below.

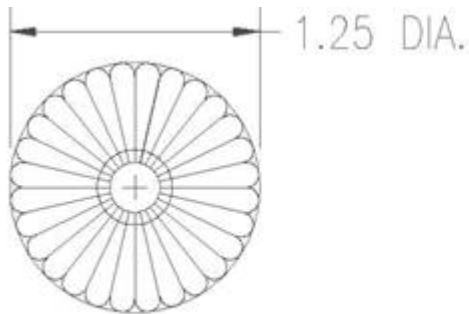

FIGURE 1

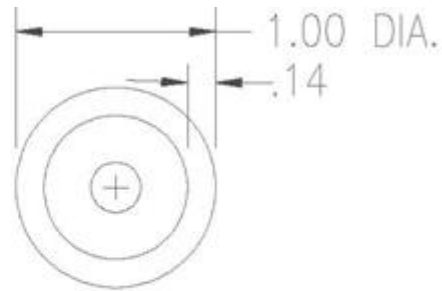

FIGURE 2

1. Thoroughly clean out seal frame and outlet gate areas where seals will seat.
2. Completely close the door.
3. Beginning with the rear seal, slide the seal into the seal frame and tap into final position with a hammer and punch.
4. Repeat for the front seal.
5. Insert the side seals and tap into place with a hammer and punch.
6. Reinsert the pipe plugs and torque to 16 ft-lbs minimum.

General Maintenance:

Cleaning:

Using a broom, air gun, or water hose (if acceptable) clean out the following places:

1. Clean front interior of outlet of any commodity build-up.
2. Clean all door tracks and door plate.
3. Clean seals and seal area (see seal maintenance).

For commodities (cement, fly ash, etc.) that build up excessively, it is recommended that you clean or remove commodity build-up whenever necessary. This will eliminate any potential operational problems.

Lubrication:

Periodically grease bearings. Grease fittings are located near the operating handle on both sides of the gate.

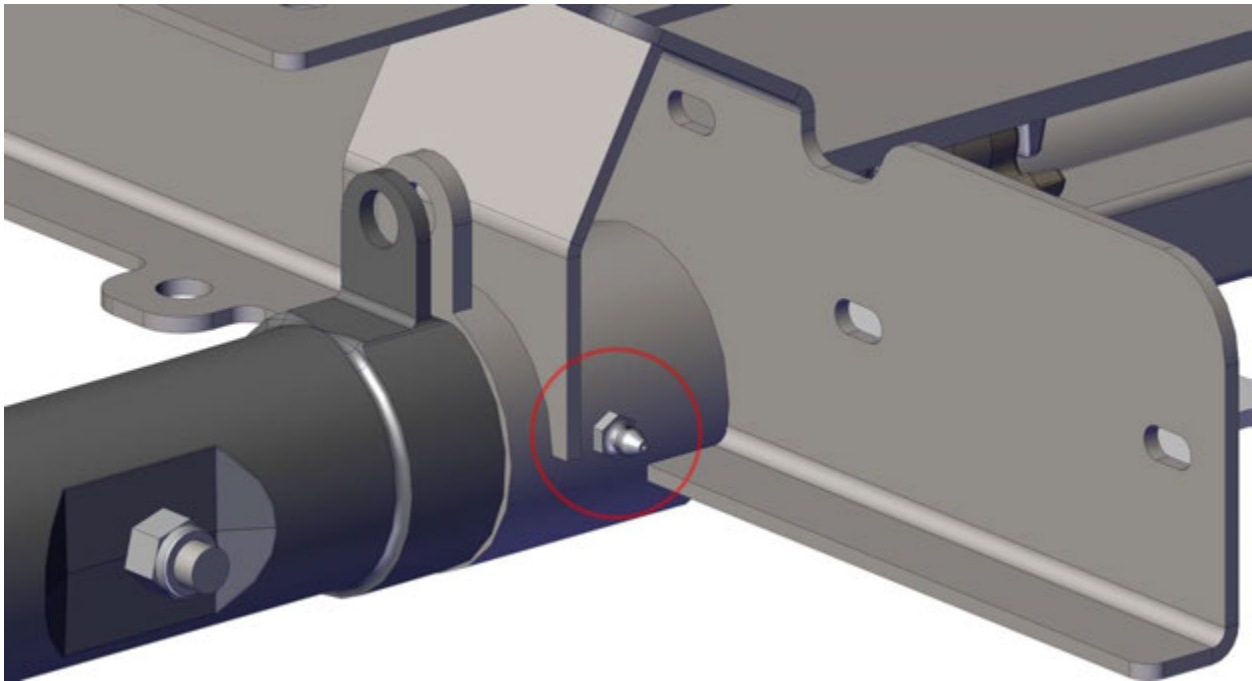



Section 6

AutoLOK™ I Discharge Gate

Section 6

Troubleshooting

If the Gate Does Not Open:

Manually depress the lock lever with a bar until it is below the door cutout. Attempt to operate the gate. See pages 5 - 7 for part location and operation of opening gate. Outlet gate may need to be re-timed per page 10. If the gate still will not open, a come-along can be used to pull the door open using the pull hole on the door.

If the Gate Does Not Close

Check front of gate for commodity build-up. Clean front and door tracks if necessary. Ensure front Carpet Seal is not sagging. If gate needs to be re-timed, see page 10 for assistance.

CAUTION

1. DO NOT strike or use heat on outlet gate or door to force unit open.
2. Use of powered gate opening units to force doors open may damage outlet gate.
3. Use of other mechanical devices (Car pullers, hydraulic jacks) to open units may damage outlet gate.
4. Use recommended operating procedures specified in this manual.

NEED HELP?

For further assistance or information, contact Miner at 630-232-3000.
Please have your gate model number handy.