

MINER TP-17 DRAFT GEAR

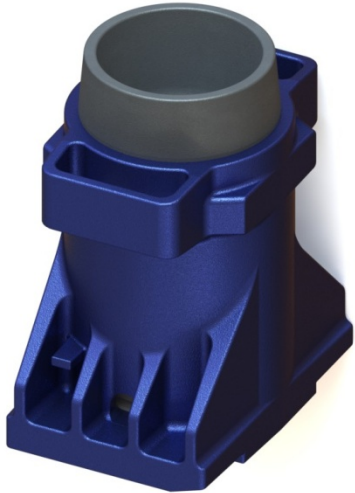

- A unique small pocket draft gear designed for smooth buffer type cushioning performance
- Commonly used in short pocket ore car applications
- Can be adapted to various pocket lengths and performance criteria (non-AAR applications).

Stroke	2.50 in	64 mm
Energy Capacity	52 kft*lbs	70 kJ
Energy Absorption	50 %	50 %

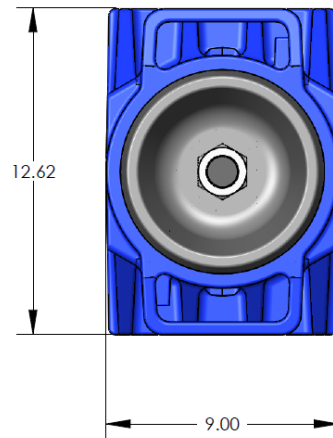
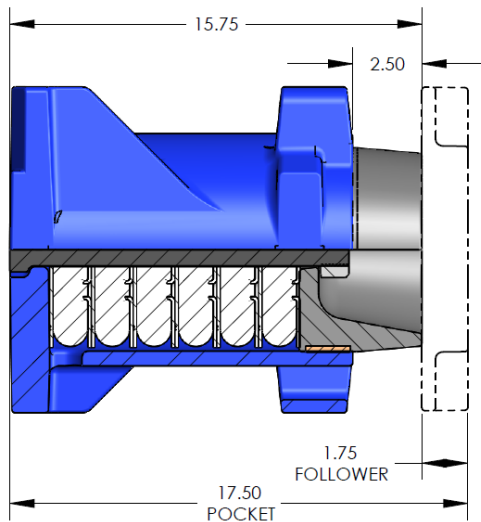

Gear Weight: 210 lbs.

TP-17 Drop Hammer Performance

