

## THE AMAZING STORY OF THE MINER TANDEM SPRING DRAFT RIGGING







## *Major Losses in Damage Dollars*

# The Evolution of Early Draft Gear Designs

*By John Schaerli & Don Arends*

The record of development of draft gears is largely contained in the numerous designs which appeared on the market in the 1800's. Different principles were used in early designs due to slower speeds, and lighter weight trains. As the size of cars, the speed of trains and the number of cars per train increased, major draft gear developments were needed.

Spring draft gears filled a special need during the railroad's transition from wooden framed cars to steel frames and standardization of draft gear pockets, automatic couplers, and braking systems. Once this period of evolution from approximately 1885 to 1919 was over, spring gears faded from the picture.

The existence of many different car designs, lack of standardization in couplers, and different draft gear pocket sizes encouraged many inventors to compete for draft gear business. The genius of Mr. William H. Miner's Tandem Springs concept grabbed the leadership in providing draft gear

solutions that extended the operating life of wooden cars with different pocket configurations and saved railroads millions of maintenance dollars.

Safety became another catalyst for the need for improved draft gears and to solve problems incident to the introduction of automatic couplers and air brakes. An Iowa farmer, Lorenzo S. Coffin (1823-1915), a former teacher and Civil War chaplain to the 32nd Iowa Infantry, was appalled at the loss of life and limb suffered by trainmen and brakemen in the 1870's. He led the reform to force railroad officials to use new couplers and air brakes to improve railroad safety. The basic coupler design, still in use today, worked like hooked fingers of two hands. The Railroad Safety Appliance Act of March 1893, approved by President Benjamin Harrison (1837-1901), required all trains to be equipped with automatic couplers and air brakes. The improvement in railroad safety was dramatic. An accident rate as high as 30,000 in 1881 was cut almost immediately by 60%.



# 19th Century Railroad Wisdom Fits 21st Century Railcar Needs

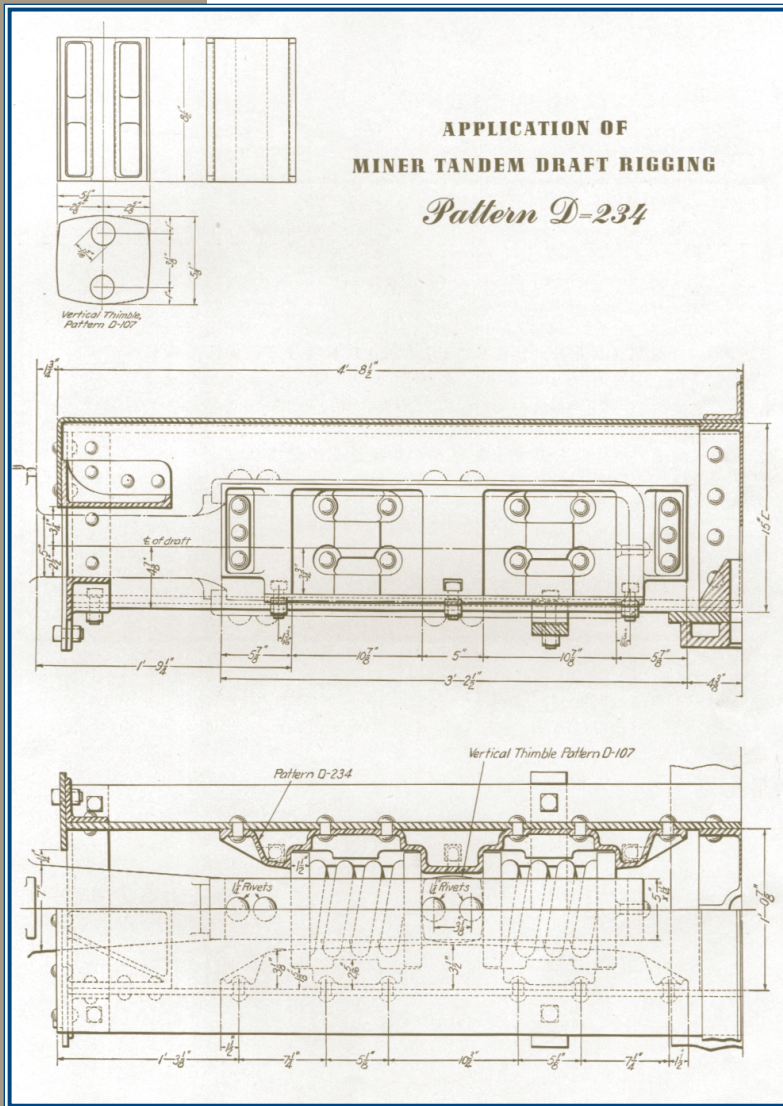

“The object of my invention is to provide a draft-rigging of a simple, strong, and efficient construction, embodying great buffing and pulling resistance, and providing for a gradual or cushioned absorption and transmission of strains and shocks to the body of the car.

To this end my invention consists of a draw-bar having springs arranged tandem between the draw-timbers and through which the strains and shocks, either pulling or buffing, are gradually absorbed and transmitted to the draft-timbers.”

William H. Miner

“In this matter of conserving railway revenue it is essential that the draft gear should be a scientific mechanical appliance with the same degree of care represented in its design, material and construction as should be embodied in a high duty machine tool.”

# *An Overview of Railroad Challenges 1891-1921*

---

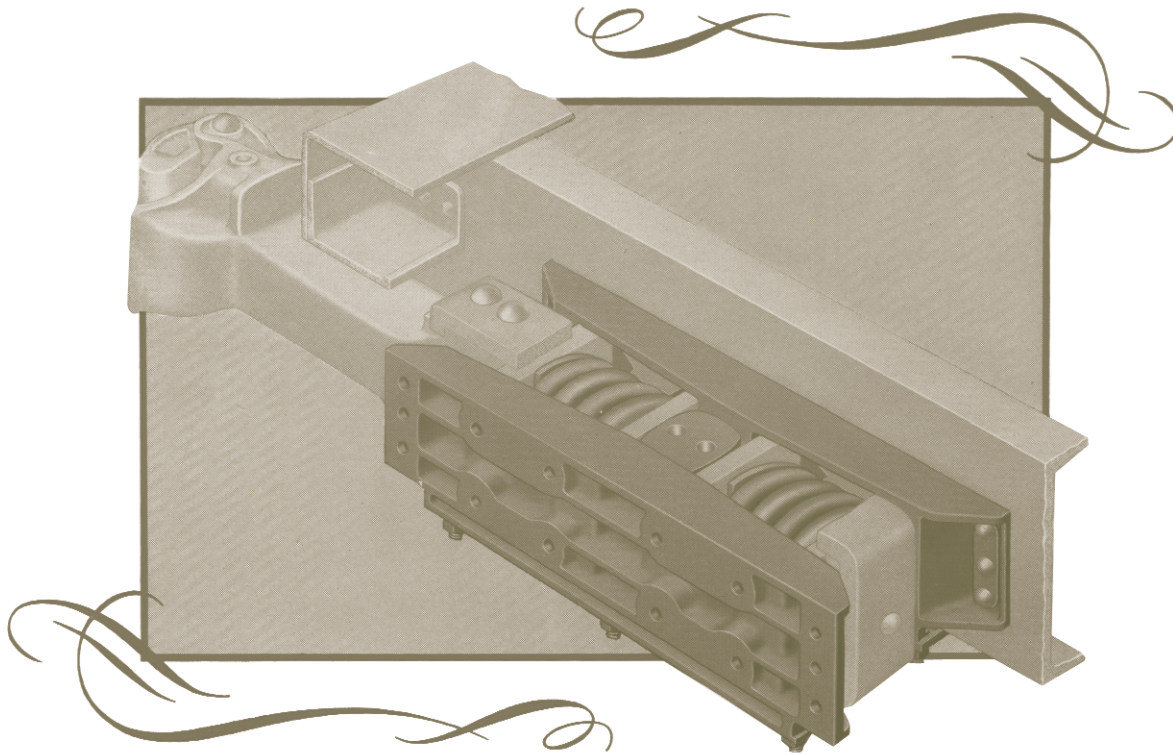

It is said that the “theater of the mind” is the greatest theater. Radio and the images it causes to conjure up in the mind of the listener is an example. Mr. William H. Miner envisioned, in his innovative mind, solutions for impact problems on 1890-1920 railroads’ fleet of wooden cars. Based on the historical facts, this is how Mr. Miner solved these challenges with patented tandem spring draft gear designs.

Imagine...The railroad industry in the late 1800’s, early 1900’s as a combination of the airline businesses, space exploration, and the computer industries of the late 1900’s. It was where the technology was being developed, where the best minds were going, where large amounts of capital was going, and where fortunes were being made and lost.

Due to the vast space of the North American Continent, locomotives got bigger, therefore, cars could get bigger and trains become longer. Back in the real world, however, there were problems. Beginning in 1879, a series was started called “Car Builders’ Dictionary,” which is still published today. This series was intended both as a dictionary, so everyone in the industry could call a yoke a yoke, and to standardize, via Master Car Builders (now A.A.R.) rules, the design of the rolling stock (cars) so that the cars of any number of railroad/car builders could all be assembled into a single train.

So as we sit and imagine the industry in the late 1800’s, the technology (cars, locomotives) is changing very fast – almost yearly – it’s bigger and faster, and there is a problem with commonality of equipment. The connectors between cars may be at different heights, and the draft gear pocket may be a different size, etc.

How can a component supplier, perhaps a draft gear supplier, survive in such a climate? Prior to 1890, as evidenced by the CBD and several railroad history books, there are any number of draft gear type devices. Westinghouse patented the first friction draft gear in 1887. With the exception of the friction gear, most draft gear devices are inadequate from a performance view and it is suspected they can’t be easily adapted to the multitude of different pockets. It is stated that the friction draft gear of Westinghouse was not widely accepted until about 1905 when approximately 150,000 were in service. It has been suggested that Westinghouse’s gear was expensive (about \$30 each), was too stiff for wooden car frames, and may not have fit in some pockets. Somewhere between 1905-1914, the pocket and coupler height were standardized and few new wood sill cars were manufactured, as steel replaced wood as the material of choice. But that’s getting ahead of the story.



# Miner's Major Breakthrough

In the early 1890's, it was well known to employ springs in draft gear-like devices. Single springs were employed or multiple springs were nested side by side and one spring in front of the other – a type of tandem spring arrangement.

Into this environment a patent was issued to Mr. W. H. Miner on October 20, 1891 for a true tandem spring draft gear, setting the stage for a product run of 30 years and a corporation which prospers today. Before beginning a discussion of the birth, life and death of the tandem spring draft gear of the W. H. Miner Co., it is necessary to appreciate the raw data which was involved. First, there is a forest of patents issuing between 1891 and 1921 mostly to W. H. Miner Co., but some are obviously acquired. Second, dry material is difficult to read because of the style, and early on the same word is not always used to describe the same part from patent to patent. Initially about 100 patents were examined and reviewed for content. Employing actual manufacturing drawings generated between 1898 and 1918, the forest of about 100 patents was trimmed back to 25 – those whose technology was used in the manufacture of the tandem spring gear during its product life. Fortunately, this task was relatively straight forward since the patent law then and now obligates a manufacturer to place the patent numbers on the product – the manufacturing drawings instructed the foundry as to which numbers went on which gear.

In parallel with the drawing and patent studies, all of the Car Builders Dictionaries were studied beginning with the 1895 edition through the 1922 edition. Specifically W. H. Miner's advertisements, the number of ads, the type of cars, and construction of the cars were noted.

Interestingly, this technology seems to peak about 1909 and the last ad for a tandem spring was in 1916 for a steel sill railroad car. The last ad for a tandem spring gear and a wood sill car was in 1912.

In a reference that was consulted, it was stated that only the most viable commercial products a company had, would have been run in the Car Builders' Dictionary. According to a 1936 Purdue article, the W. H. Miner Co. manufactured about 4,000,000 tandem spring draft gears customized to fit individual car builder designs.

How did the Miner Co. accomplish this with technology which sometimes didn't have enough energy absorption capacity and frequently returned too much energy back to the system (recoil)? We're not sure, but imagine it was a combination of cost, modularity, and an engineering department which was organized. We can imagine as to cost; modularity, however, we have an idea. It appears that the springs were standardized by the mid-to late-1890's. The followers and yokes were standardized in 1905-1907. From an examination of actual manufacturing drawings between 1905-1907, springs, followers, and yokes are not given pattern numbers suggesting they are off the shelf items. The same group of drawings from January 1905 – June 1907, show that the Miner engineers designed, built, and sold at least 44 different "flavors" of tandem spring gears. Different gears were being sold for passenger cars, for freight cars and for locomotives having wood, steel and wood/steel sills. It was the stop castings which were varied to fit the environment of the pocket. All other parts were standard, i.e. modularity.

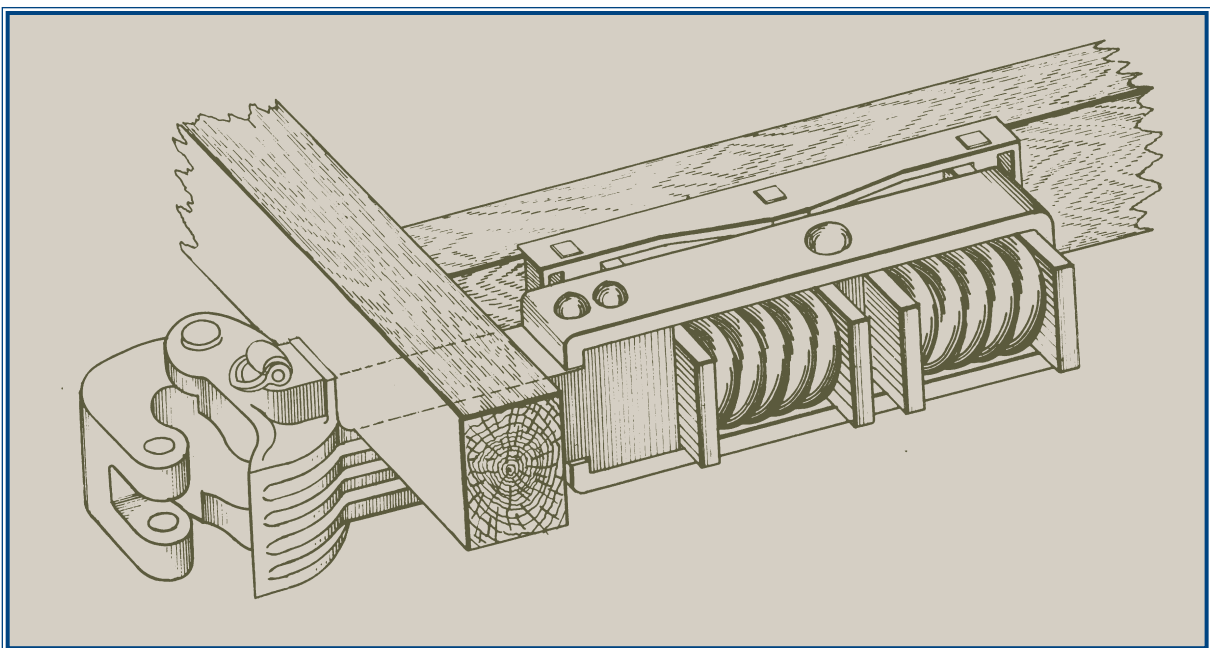



# Innovative Patents Made the Difference

It is now necessary to instill a basic understanding of a tandem spring draft gear which is not a complex device.

It starts with drawings from two patents – the original patent 461,443 dated October 20, 1891; and one approximately ten years later 668,656 dated February 26, 1901. For this basic purpose we have two devices, the first almost a toy compared to the second ten years later, the same inventor/engineer on both. This leap in technology reflects the progress taking place in the industry.

It should be noted that both patents show wood draft timbers, but 461,443 shows a coupler that needed a man to go between the cars to insert/remove a pin. In the 668,656 patent there is an automatic coupler still used today.

Spring draft gears prior to 461,443 used springs in various arrangements within the pocket. However, single springs did not have sufficient capacity, and side-by-side springs were not able to fit into all pockets.

Patent number 461,443 teaches a system that includes: (1) spring groups (green), one in front of the other, or “tandem” occupying a small amount of space, linked with a half yoke and a rod (orange), so that the capacity of all the springs are available in either buff or draft; (2) stop castings (red) which are bolted to the wood draft timbers in a manner to define spring enclosures; and (3) within each spring enclosure are a front and a rear follower (yellow).

## United States Patent 461,443

**Problem:** Single springs did not have sufficient capacity.

**Solution:** Place springs one in front of the other (but make them work independently and not just have the equivalent of one long spring), so the full capacity of the springs works in either buff or draft with front and rear followers.

**NOTE:**  
All patents shown are available at:  
[www.uspto.gov](http://www.uspto.gov)

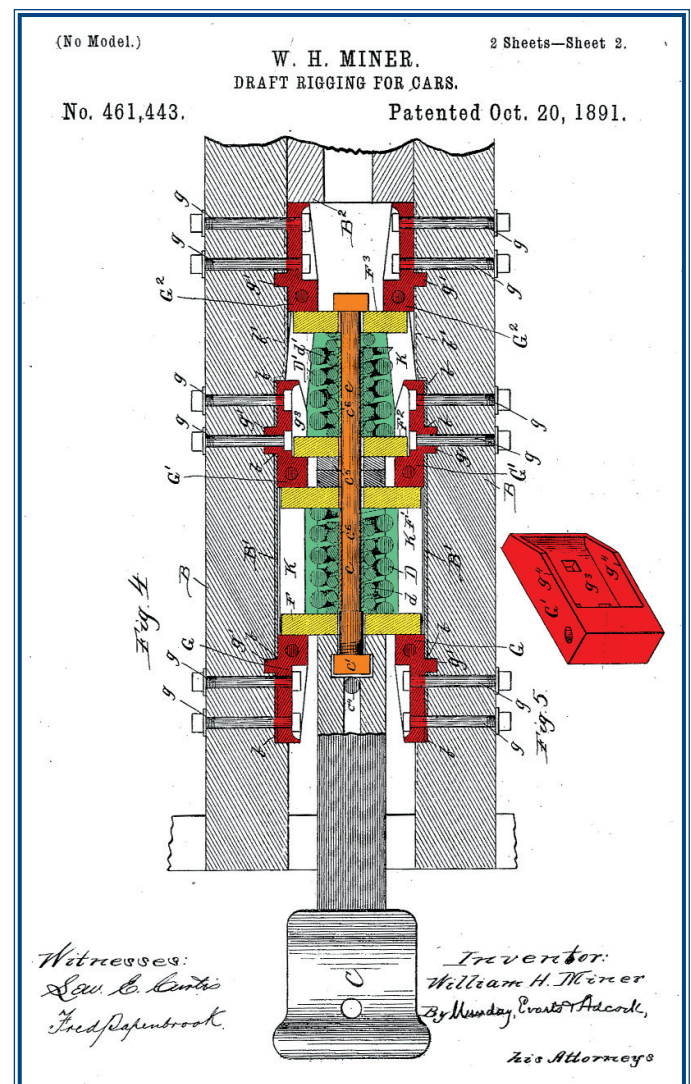



# Ten Years of Continuing Progress

Approximately ten years later is Patent number 668,656. The function is the same as 461,443 but the mechanical systems have been improved; (1) spring groups (green) in tandem are now linked by just a yoke (blue); (2) two stop castings (red), one bolted to each side of the pocket; (3) within each spring enclosure are a front and rear follower (yellow).

Between July 7, 1905 and 1921, Miner built and sold 13 different flavors of tandem spring draft gears, which were stamped with the 461,443 number and 26 flavors which were stamped with the 668,656 number. What changes in the 44 different flavors studied between January 1905 and June 1907 is the stop casting (red). What this suggests is because the pocket and height had not standardized (which happened around 1911-1914), car builders were building cars with pockets of many different sizes and at different distances above the ground.

## United States Patent 668,656

**Problem:** Need for stronger design.

**Solution:** The Draft Gear is designed for a locomotive tender having a pocket formed of wood timbers. The invention is in the heavy-duty stop casting (red) shown in Figs. 5 and 6. This stop casting is designed to engage the end sill and the body-bolster of the locomotive, as well as the wood walls of the pocket. Probably to provide additional strength, the top edges (see Fig. 3) contact to form a steel pocket within the wood pocket of the tender.

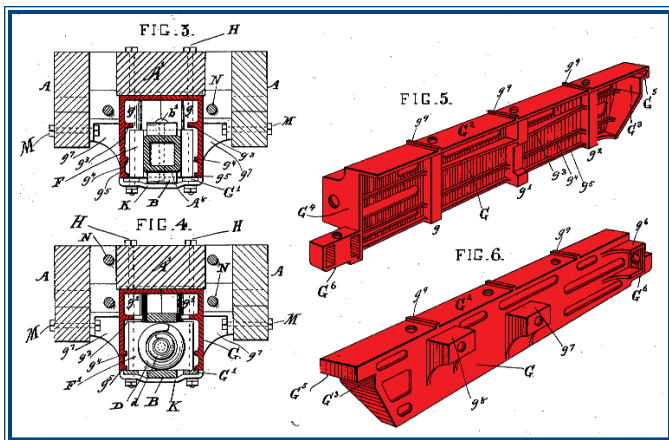

It thus can be imagined that knowing the type of car – wood, steel, or mixed construction — and most importantly, the height, size of the pocket and arrangement of the draft timbers, the design of a tandem spring draft gear was straight forward.

The followers, springs, spring enclosure, and custom yoke are a given, i.e., standard items. The stop casting is then modified to fit the car pocket and accommodate the standard items. It is altogether possible that designing stop castings over time led to the establishment of a “data base” in that an existing design fit or almost fit a new design pocket. The new tandem spring gear was then cheap and quick to manufacture.

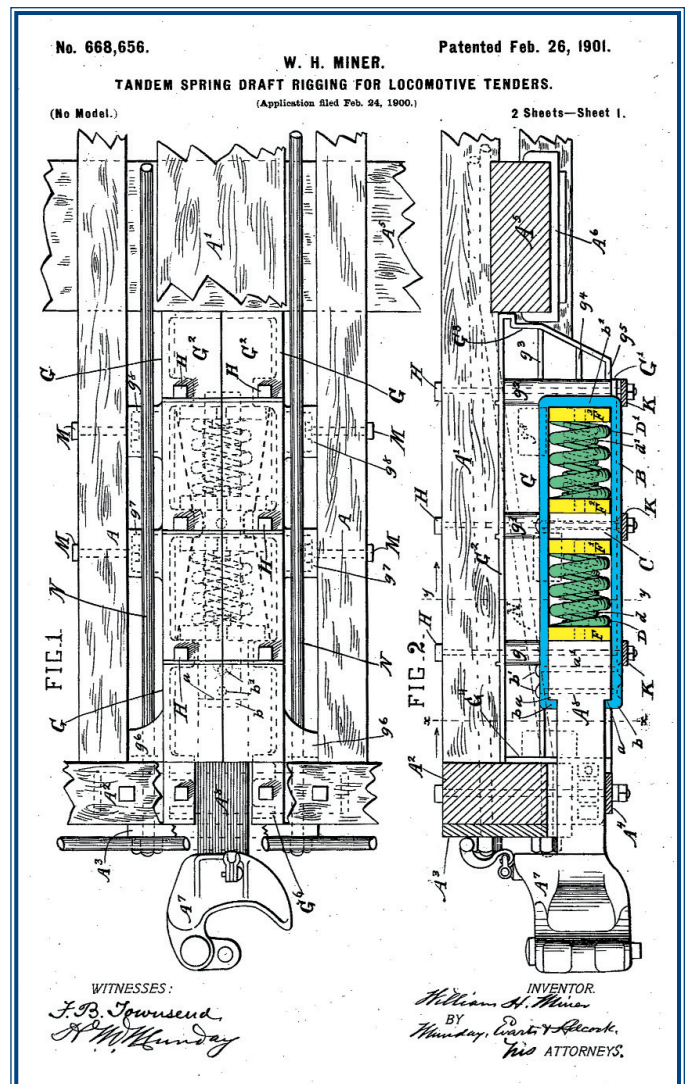



# Miner Innovative Patents

## United States Patent 474,996

**Problem:** Convert the multi-piece stop casting of the first Miner tandem draft gear design USP 461,443 into a single unit.

**Solution:** In Miner's first patent, USP 461,443 on page 6. Note in Fig. 4, a steel plate which is between the stop castings (red) and the wall of the pocket. The stop casting (red) itself is comprised of 6 individual pieces, one of which is shown in Fig. 5 (red).

Miner in his second patent disclosed a single piece stop casting (red) in Figs. 5 & 6 that is all the individual pieces and steel plate have been combined into a single unit. A feature in Fig. 5 is the guide bar (orange). The method of placing a tandem spring gear in a pocket was to first bolt into place the stop castings, then all the other items, i.e., followers, springs, stop castings, etc., were inserted from below. Two guide bars, one on each side, were then bolted to the bottom of the stop castings to hold all the items in place. In the future, these guide bars will be the subject of several patents.

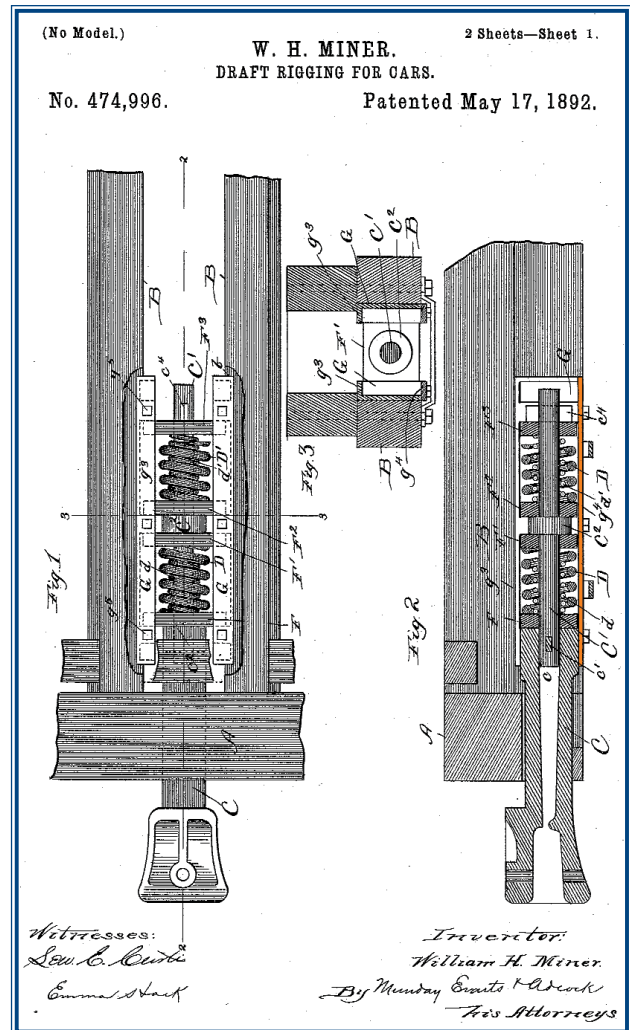
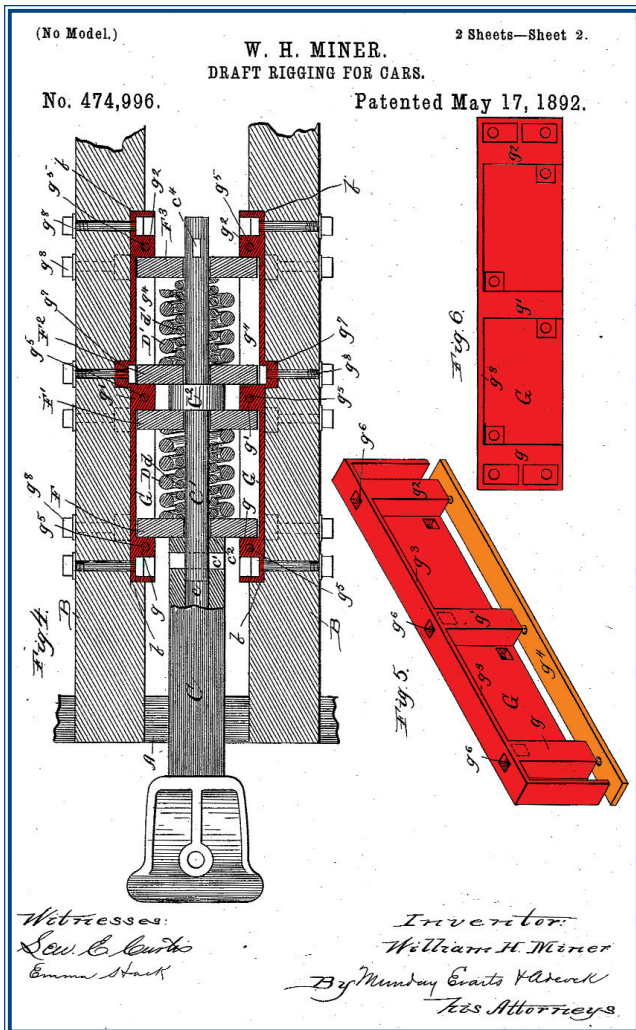

## United States Patent 549,207

**Problem:** Make repair work within the car pocket easier.

**Solution:** Use a two-piece yoke (blue) as shown in Figs. 1 (a side view) and 2 (a top view). Four bolts hold them together. The rod of prior patents is gone and will not be used again over the life of the tandem spring gear. The purpose of the two-piece yoke makes repair work within the car pocket easier. Also worth noting are pins (orange), the purpose of which are to hold the springs in place during assembly from the bottom.

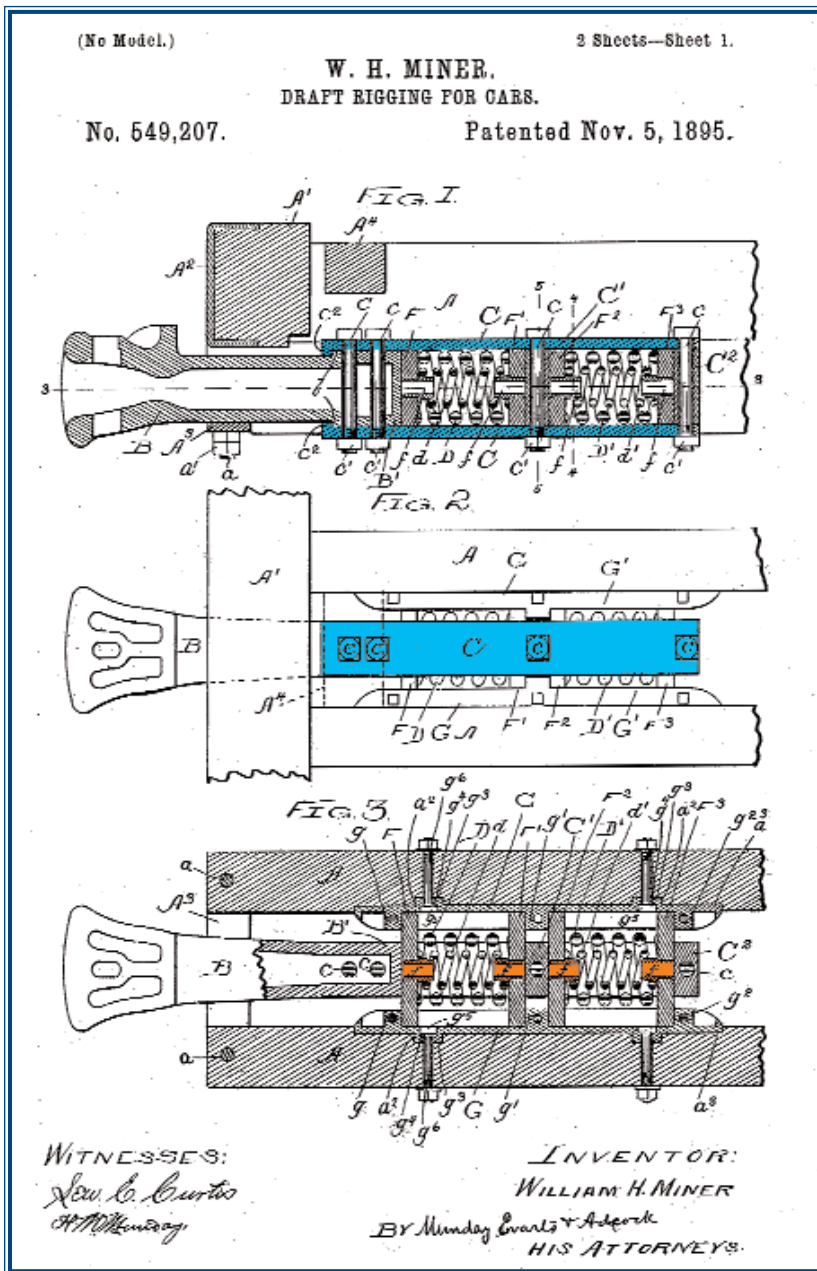



# Miner Innovative Patents

## United States Patent 570,038

**Problem:** Make it easier for steam locomotive to start moving a long string of cars.

**Solution:** Use a two-piece yoke (blue) in Figs. 1 and 2. A beefed up stop casting (red) in Fig. 6, the spring holding pins (orange) in Fig. 3. At the right side of Figs. 2 and 3, between the follower and the yoke is a space (purple). The space is employed to make it easier for the steam locomotive to start moving a long string of cars. With this device, the locomotive could move forward an inch or so before it picked up the first car, then the same distance before the second car was picked, etc., down the length of the entire train. Without the space, the locomotive would have to compress the draft gear of each car a bit so that the cars could be picked up as individuals rather than as a string. Steam locomotives could not generate much pulling power from a stopped position and this invention assured each car would be picked up as an individual. The space (purple) existed between the rear follower and the back of the yoke (blue) so that in draft (pulling by the locomotive), there is about an inch or so of freedom before the yoke engages the follower.

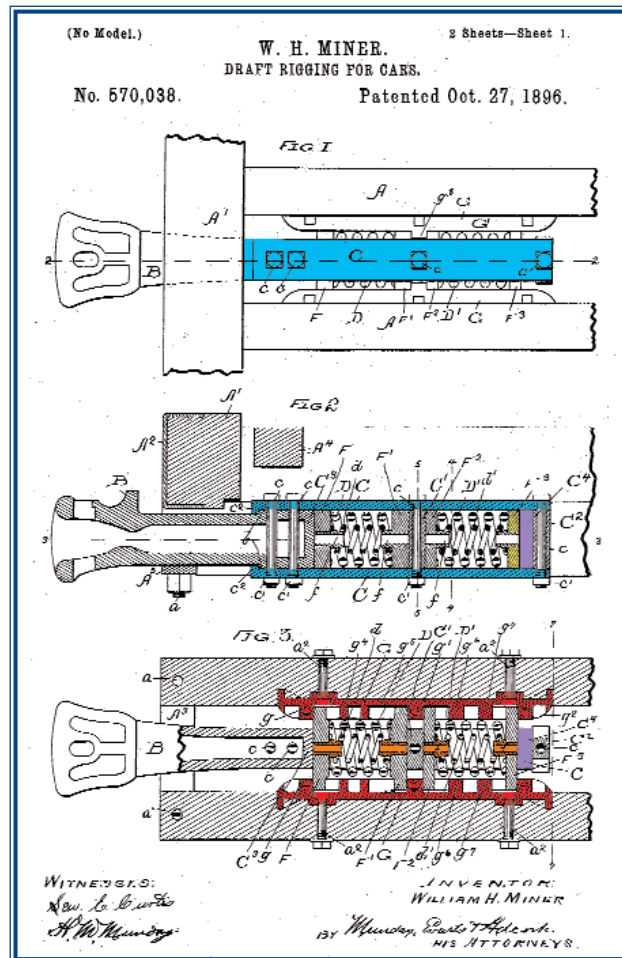
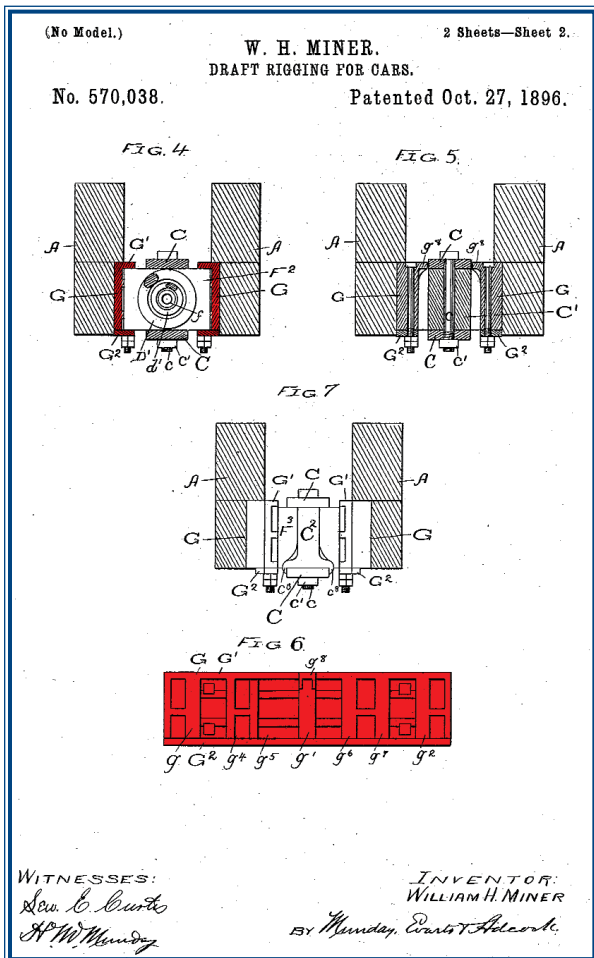

# United States Patent 668,655

**Problem:** Add a fulcrum point in the gear so that the yoke and coupler, which are bolted together solid, can pivot to allow turning in curves.

**Solution:** A fulcrum design is built into the gear so that there is a pivot point. The coupler assembly is bolted (purple) to the yoke (blue) so that the unit is one long, solid piece. There must be substantial freedom in order to negotiate track curves. The fulcrum is created by the tapered top sections of the stop casting (red) shown in Figs. 6 and 1. The yoke, having the coupler attached, is held in the pocket by the followers (yellow) and pivots around the large pin (black) in Figs. 1 and 2. This fulcrum system was used into the future on most tandem spring draft gears.

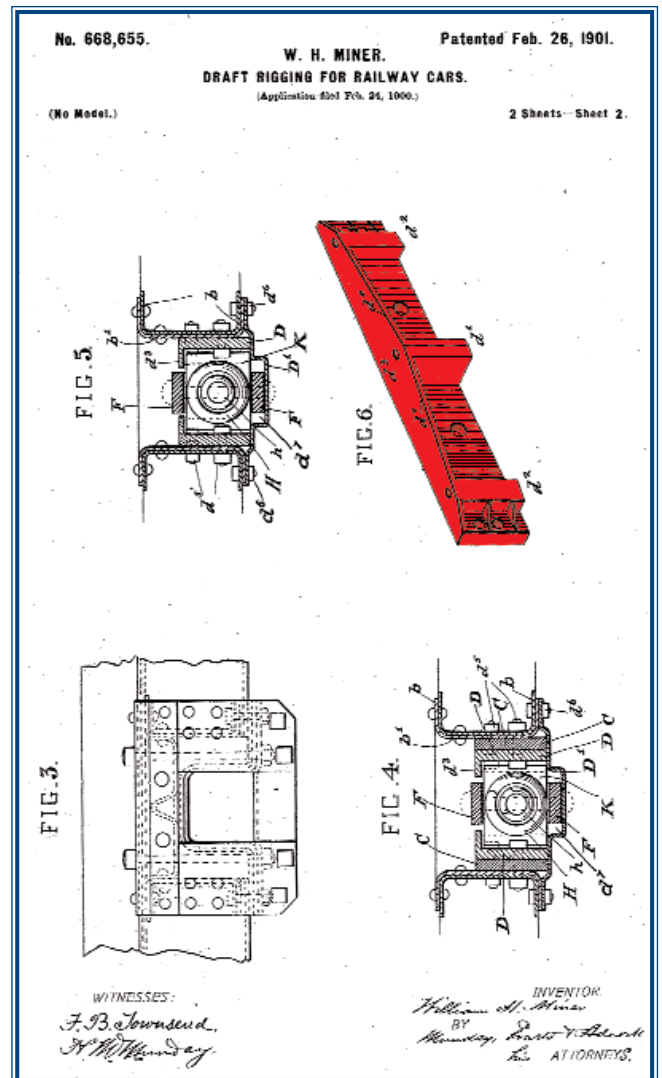
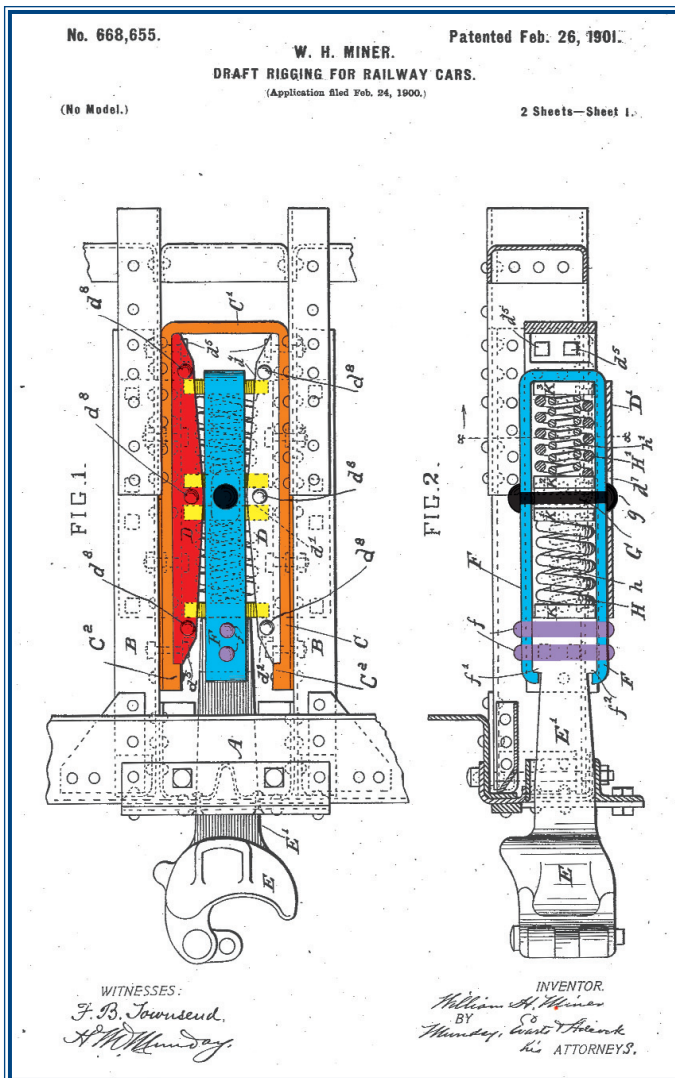



# Miner Innovative Patents

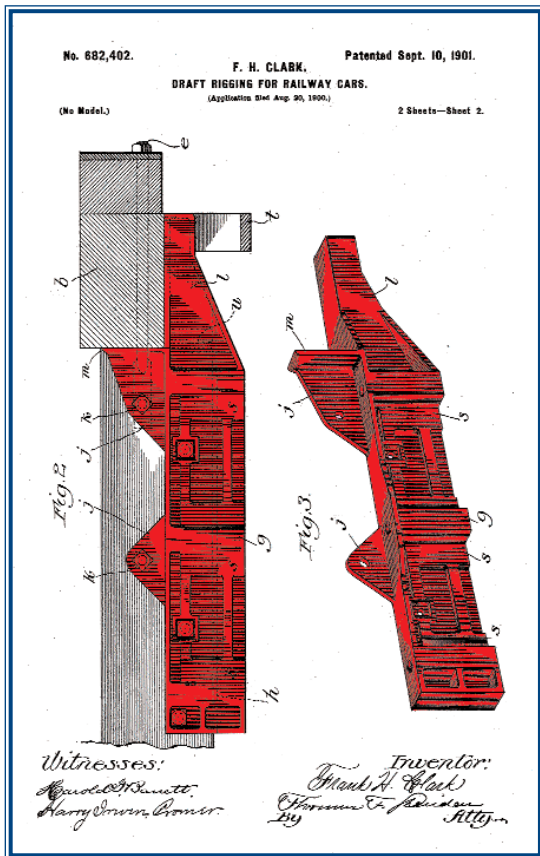

## United States Patent 682,402

**Problem:** Take a car with a weak center sill or one with no center sill and provide it with a massive reinforcing member that incorporates the tandem spring draft gear.

**Solution:** Use a heavy-duty stop casting (red) as shown in Fig. 3. The unique features are the two ears j and j/m which allow the tandem spring draft gear to be carried partially below the pocket.

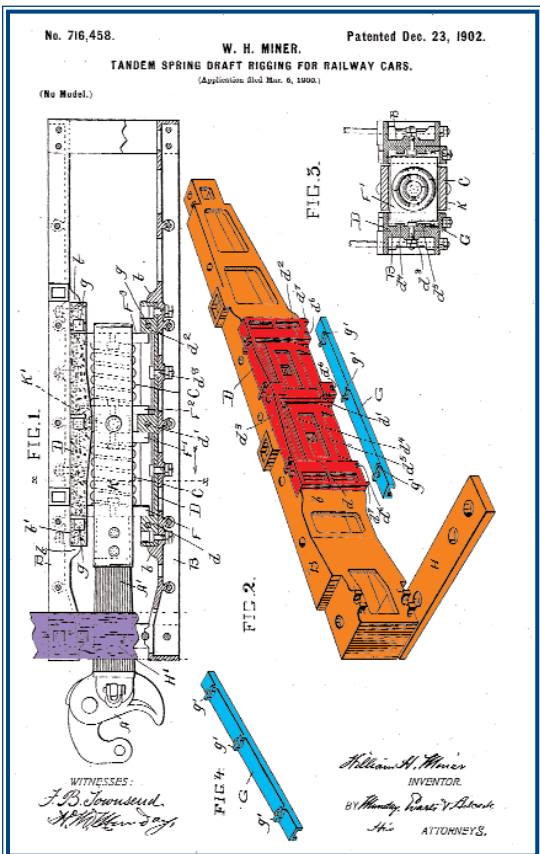

## United States Patent 716,458

**Problem:** Take a car with a weak center sill or one with no center sill and provide it with a massive reinforcing member that incorporates the tandem spring draft gear.

**Solution:** Start with a reinforcing member (orange) that bolts to the end sill (purple) at the front of the car and appears to extend into the car and connect it to the bolster. It is to be noted that the end sill (purple) is wood. The stop casting (red) bolts to the massive reinforcing member rather than to the center sill. The invention is shown in Fig. 4 (blue) and involves the guide plate. That guide plate holds the followers, springs, etc., in place after they have been assembled in the pockets created by the stop castings.

## United States Patent 754,669

**Problem:** Design a draft gear for a passenger car with both wood pocket and end sill.

**Solution:** Engineer the tandem spring gear to hang down partially under the pocket/center sill (orange) in Fig. 4. Staying with Fig. 4, the invention is in the stop casting (red) and the flanges that wrap below and on the side of the timber of the center sill.

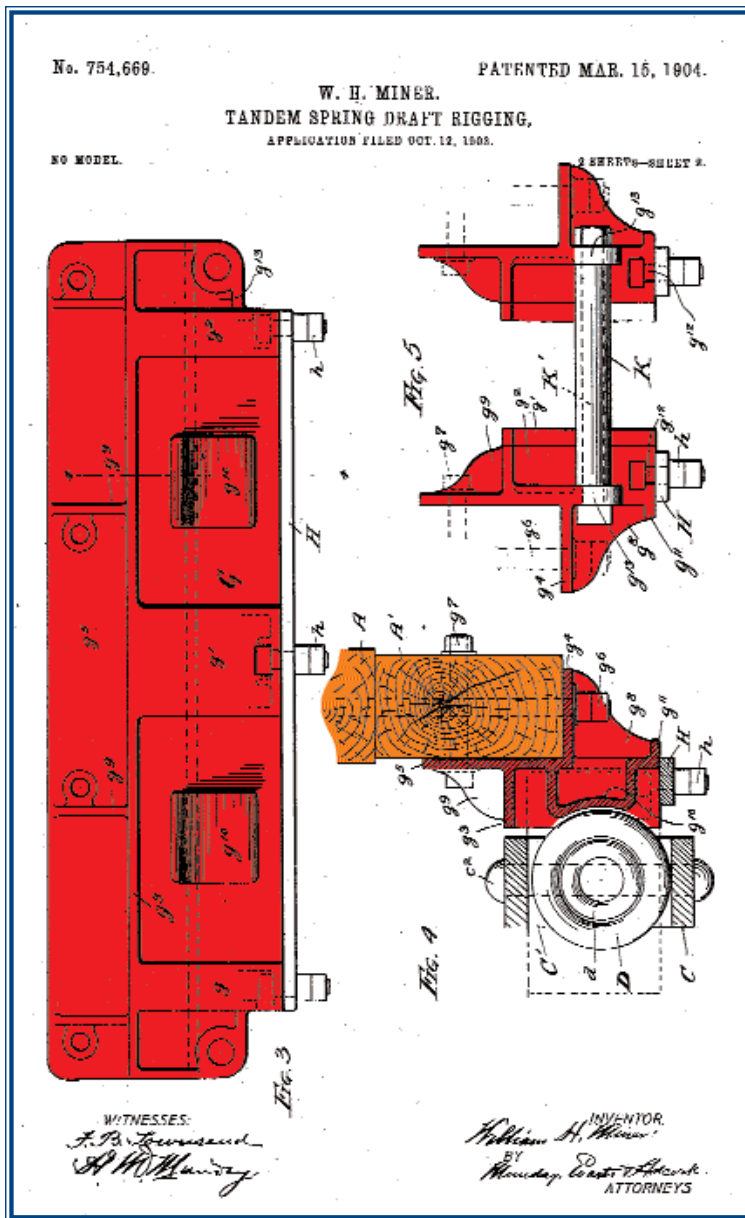

**NOTE:**  
All patents shown are available at:  
[www.uspto.gov](http://www.uspto.gov)



# Miner Innovative Patents

## United States Patent 758,144

**Problem:** Beef up the wood center sill or draft timbers so that they did not give way under extremely heavy blows or strain.

**Solution:** Referring to Figs. 1 and 2, the stop casting (red) is attached to the wood pocket. In order to transfer draft and buff forces to the body-bolster (purple) of the car, the invention is the provision of filler blocks (orange) which connect the bolster to the stop casting as shown in Figs. 1 and 2.

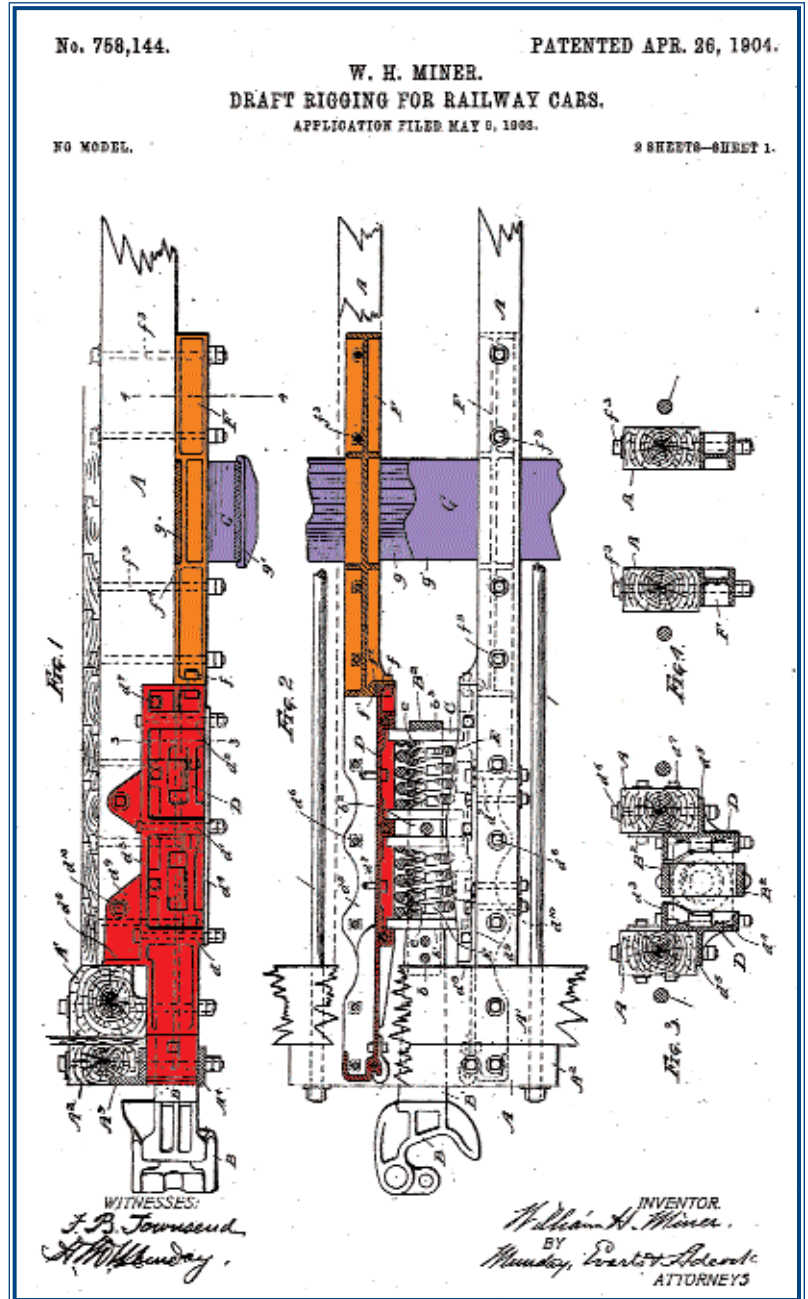

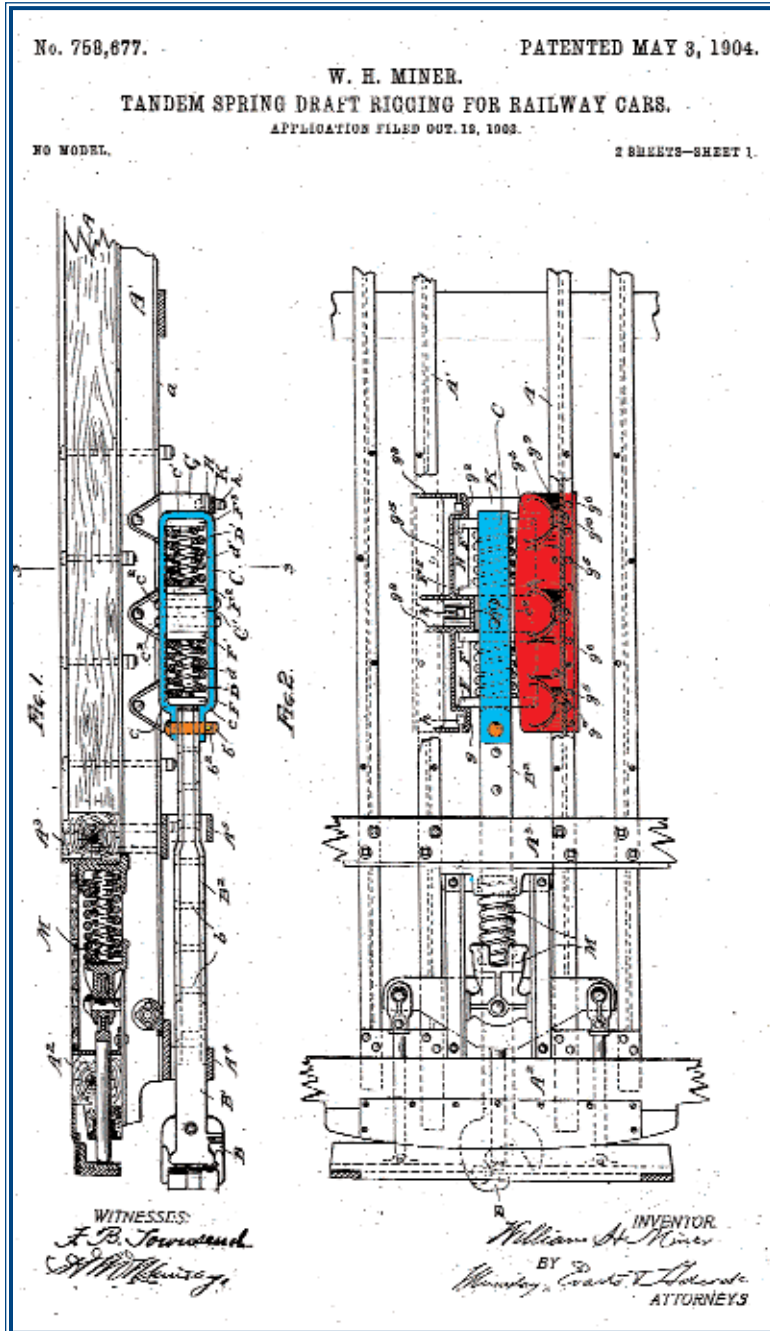

## United States Patent 758,677

**Problem:** Engineer a tandem spring gear for a passenger car.

**Solution:** The entire assembly including the coupler is designed to hang below the pocket as seen in Fig. 3. The stop casting invention is shown in red. It supports the assembly without being carried up in the pocket. Note also in Figs. 1 and 2 that the coupler is “pivotally” connected via a bolt (orange) to the yoke (blue) and that the stop castings (red) have curved inside surfaces to allow them to function as a fulcrum. These cars must have been designed to go through tight turns.



# Miner Innovative Patents

## United States Patent 769,225

**Problem:** Design a tandem spring draft gear for very heavy-duty service in steel pockets.

**Solution:** First, the pocket is steel and not wood. Second, the stop casting (red) is bridged over at the top as seen in Figs. 3 and 4 to create almost a pocket within a pocket. The stop casting (red) thus is one single piece as against two separate pieces. Of course, the bottom is still open. An interesting feature of this device is shown in Figs. 5 and 6. This feature (orange) constitutes a way of locking a bolt head so that it does not turn when the nut turned.

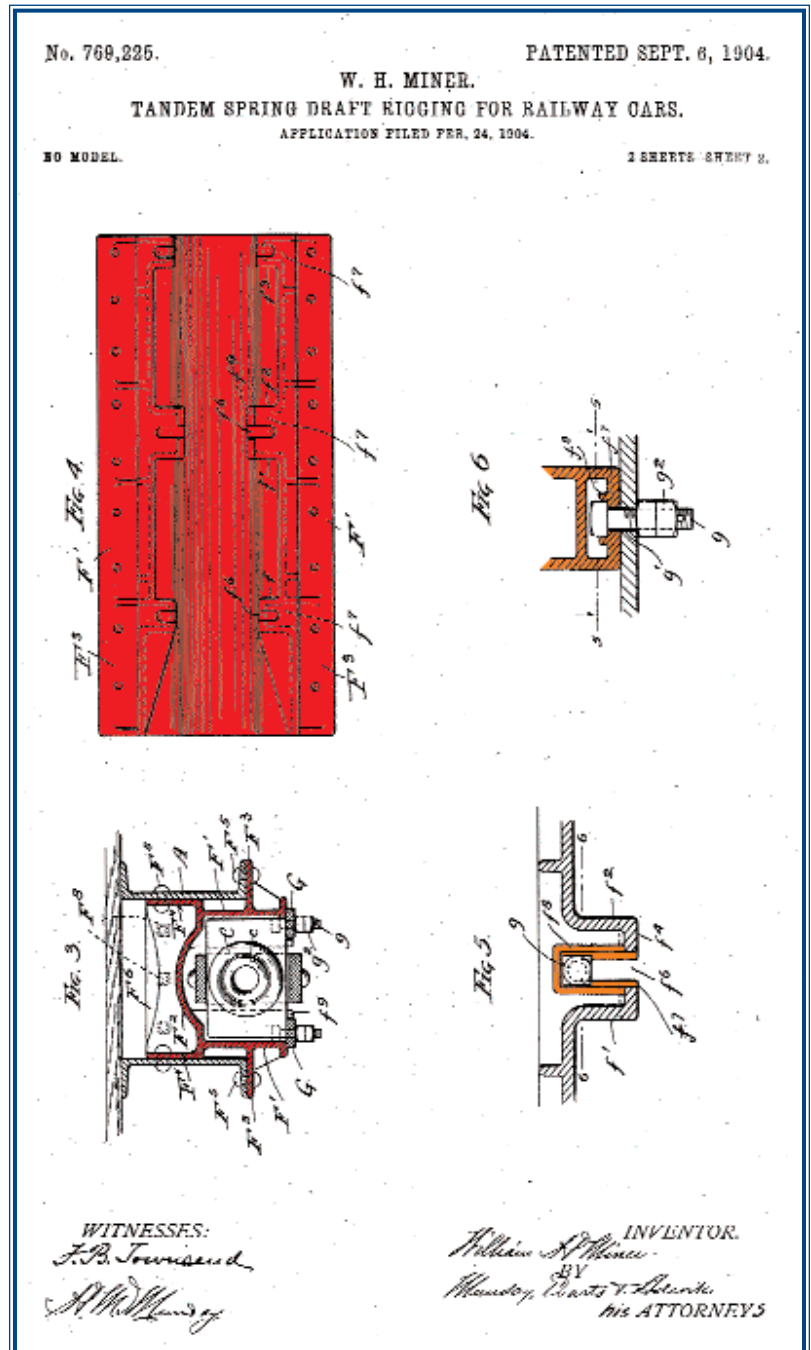

No. 783,379.

PATENTED FEB. 21, 1905.

J. R. MITCHELL.

TANDEM SPRING DRAFT RIGGING FOR RAILWAY CARS.

APPLICATION FILED SEP. 20, 1904.

2 SHEETS - SHEET 2.

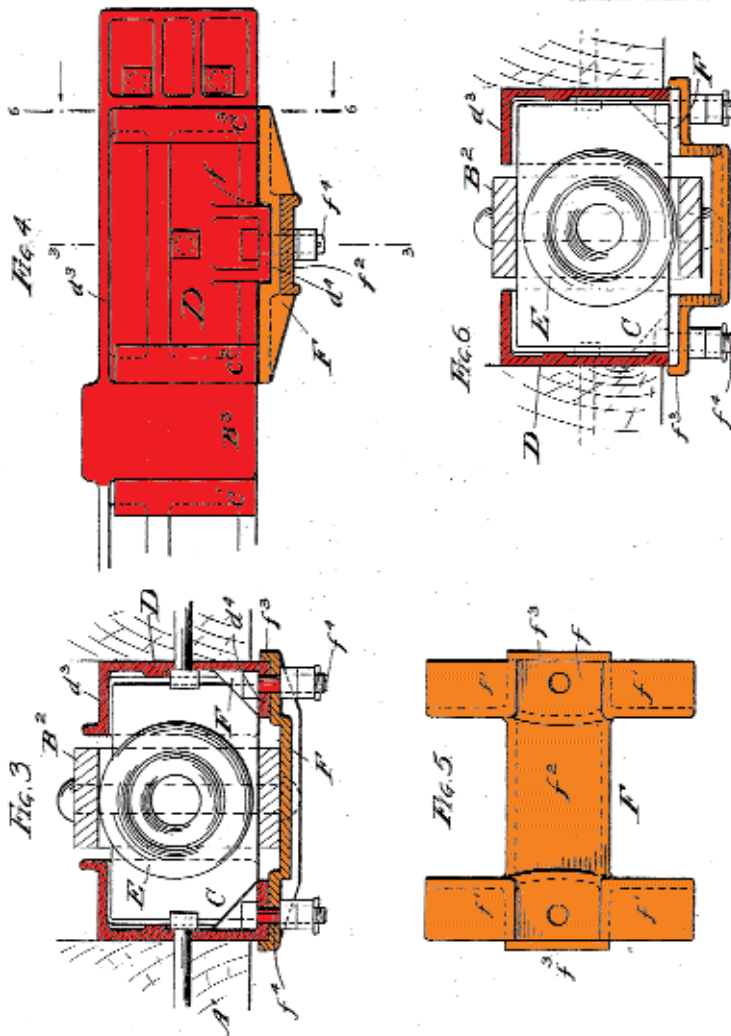

WITNESSES:  
F. B. Townsend  
H. W. Manning

INVENTOR:  
John R. Mitchell  
BY:  
Manning, Brown & Associates  
his ATTORNEYS

## United States Patent 783,379

**Problem:** Beef up earlier heavy-duty designs.

**Solution:** Mr. Miner found it necessary to beef-up the assembly in various ways including employing a removable guide/tie (orange), shown in Figs. 3 and 4, to bridge across the distance between the bottoms of the two stop castings (red) in the wood pockets.



# Miner Innovative Patents

## United States Patent 789,293

**Problem:** Design another heavy-duty stop casting that extends forward all the way to the front or cross sill (purple).

**Solution:** The invention is a removable bearing piece (orange), shown in Figs. 2 and 3, that fits into the front edge of the stop casting (red). The removable bearing piece absorbs the force of the lateral or swinging movement of the coupler draw bar. When the removable bearing piece is too worn or abraded, it is removed and replaced thus increasing the life and durability of the stop casting.

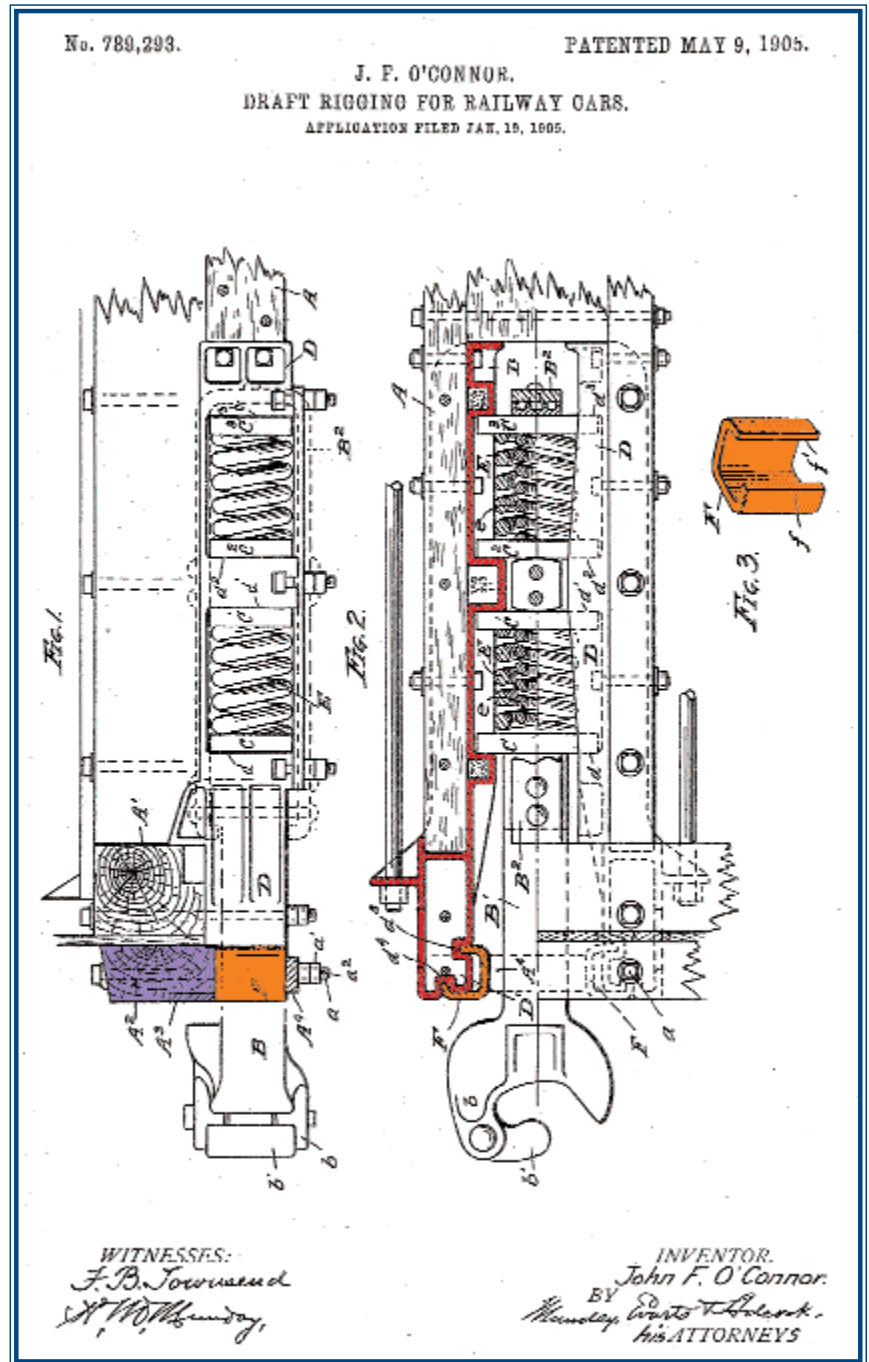

# United States Patent 792,147

**Problem:** The need for an extra strength stop casting which better distributes shock to the car.

**Solution:** Provide a tandem spring draft rigging that sits up within wood timber pocket. The front end of the stop casting (red) engages the front sill, the buffer block, and the buffer plate (all in orange). The rear end of the gear engages a filler block (purple) that extends between the sills.

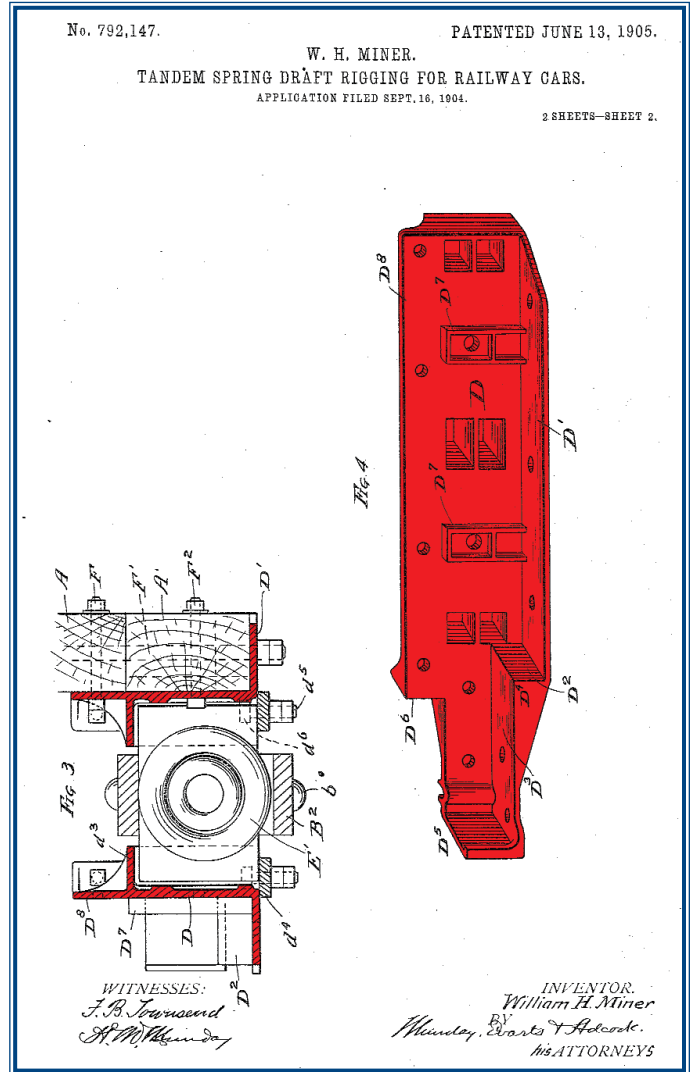
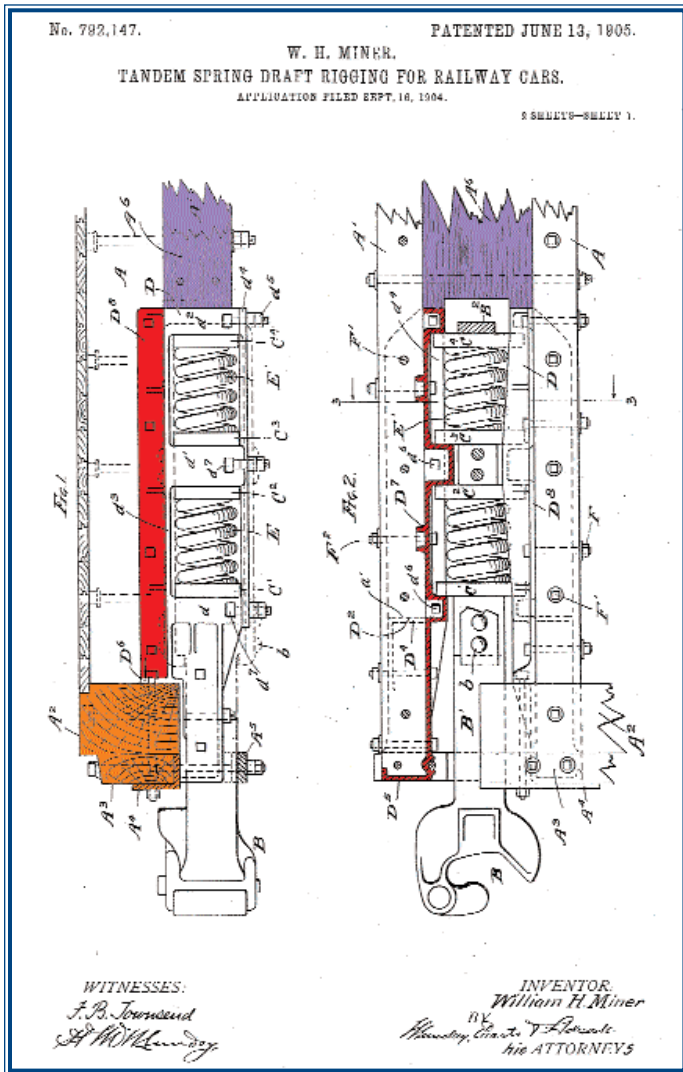



# Miner Innovative Patents

## United States Patent 792,229

**Problem:** A need for a heavy-duty stop casting in a wood pocket.

**Solution:** Wrap stop castings (red) around front sill and reshape removable guide and connecting plate (orange).

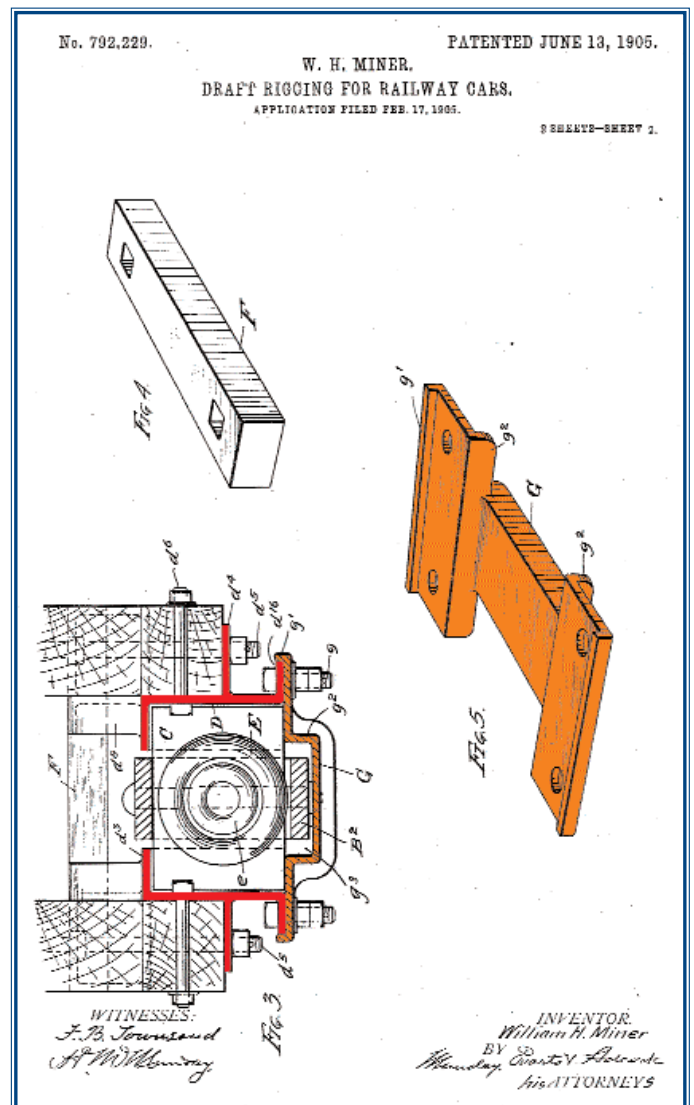
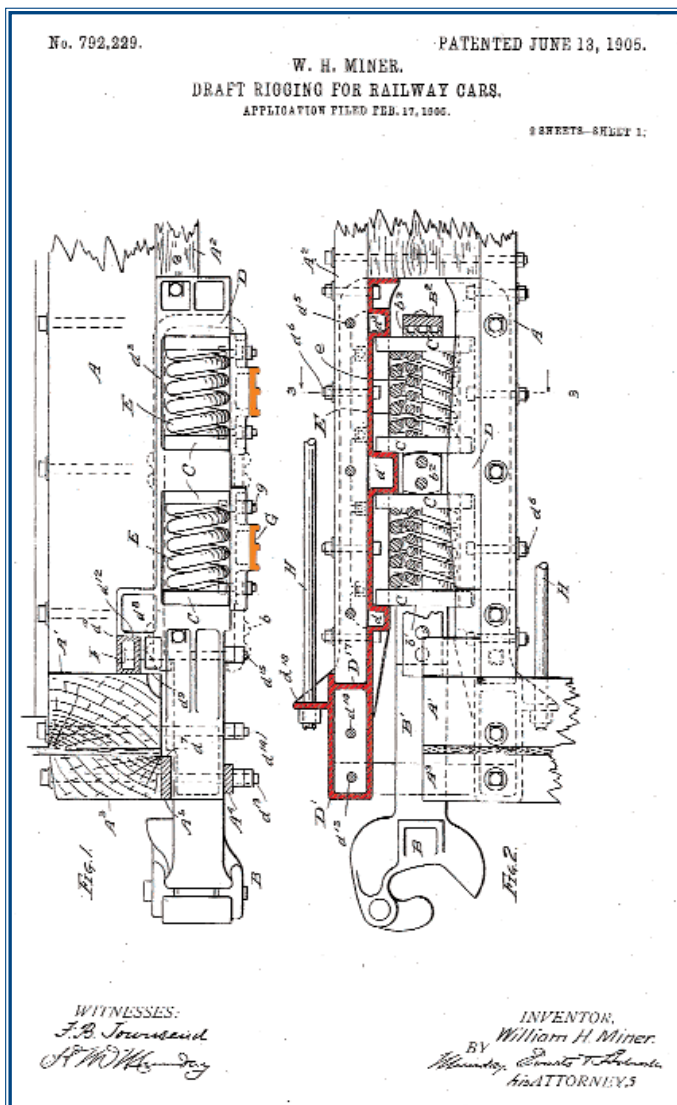

## United States Patent 799,070

**Problem:** Provide a means which overcomes misalignment in the stop castings and/or the pocket.

**Solution:** The design provides longitudinally extending slots (orange, Fig. 5) in the stop castings (red, Fig. 5) to give some freedom in bolting on the removable follower guides (purple, Fig. 3). It is to be noted that the pocket is of all steel construction. As is standard with tandem spring gears, the stop castings are fixed to the car, then all the components are stuffed in from the bottom, then the follower guides are bolted up to hold everything in place.

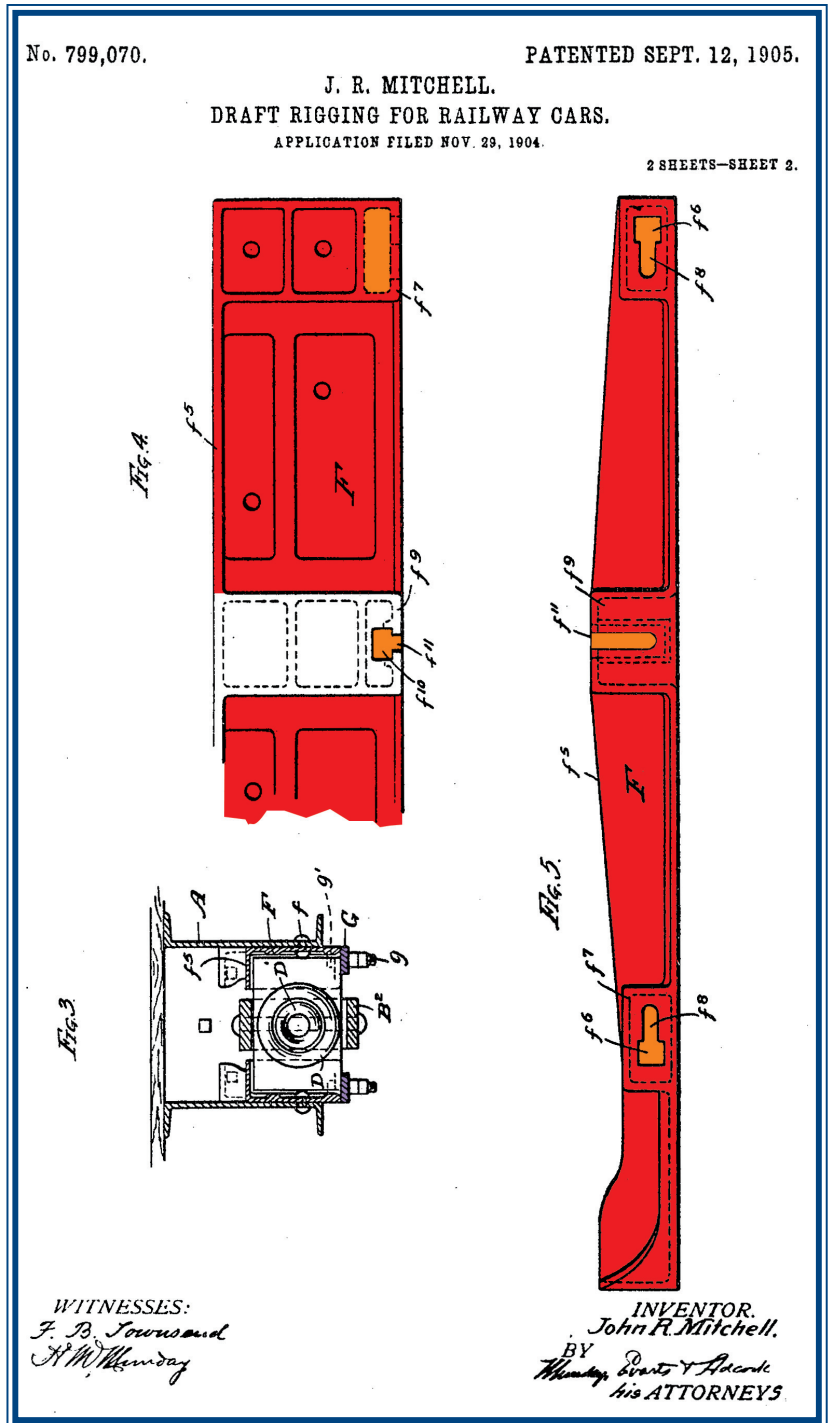



# Miner Innovative Patents

## United States Patent 799,071

**Problem:** A need to prolong the life of the stop casting.

**Solution:** Provide a replaceable shim (orange, Fig. 1) which serves to receive wear and abrasion incidented by the railway coupler as it swings back and forth. Worn shims are replaced by clipping a new shim into the front end of the stop casting.

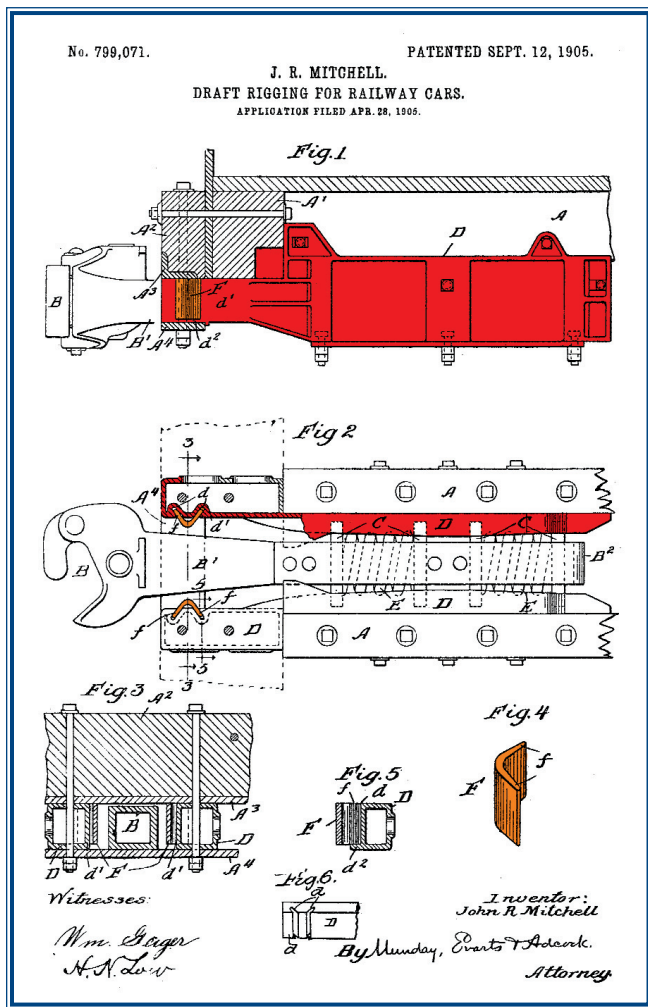

## United States Patent 829,728

**Problem:** A need for improved manufacturing of stop castings.

**Solution:** Design a stop casting (red) of malleable iron or other annealed metal and provided with the customary shoulders for the followers to abut against and which is composed throughout of a web of uniform thickness both at the shoulders as well as elsewhere. Thus, the stop casting as a whole will be entirely free from T or other sections which would result in giving the casting a greater thickness or body of metal at some points than others.

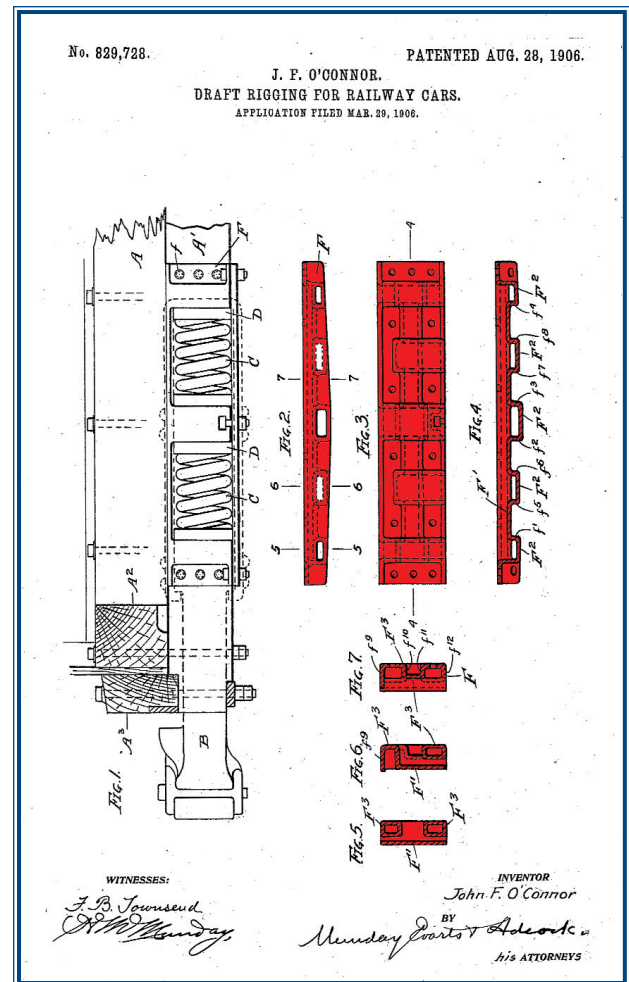

## United States Patent 829,729

**Problem:** Improve stop casting design for locomotive tenders.

**Solution:** Engineer a cast web of uniform thickness both at the stops or shoulders as well as elsewhere, so that the stop casting as a whole will be of uniform thickness and entirely free from T-sections to eliminate imperfections, casting strains and defects.

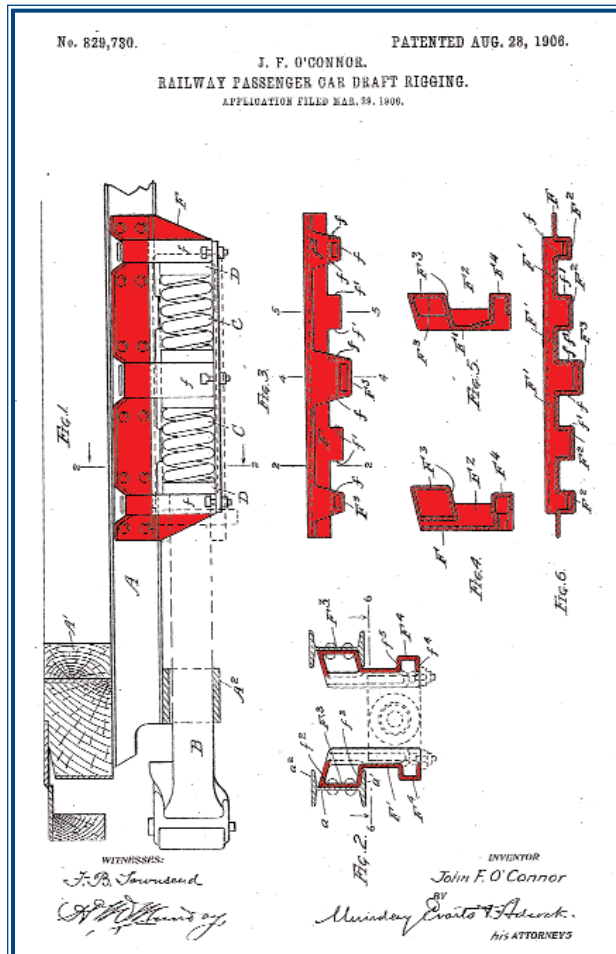
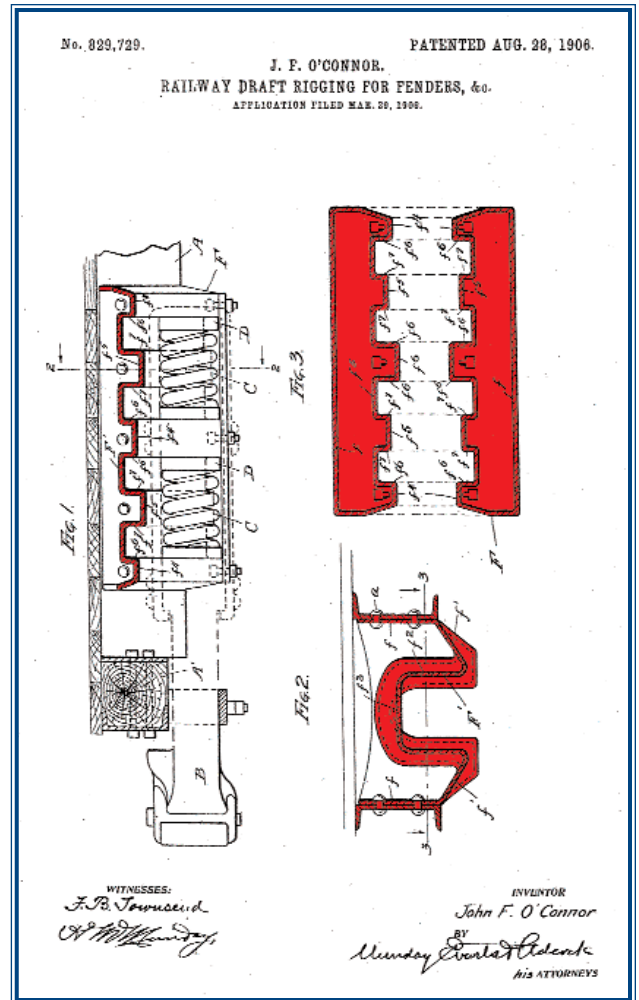

## United States Patent 829,730

**Problem:** Eliminate stress concentrations at sharp corners or "T" sections in passenger cars.

**Solution:** Design a stop casting without "T" sections.

# Miner Innovative Patents

## United States Patent 838,563

**Problem:** To better distribute buffing strains upon the center sills and the draft timbers.

**Solution:** Invent a draft rigging of a simple, strong, and efficient construction. The side plates or stop castings are very securely anchored to the car framework. Buffing strains are transmitted to the several longitudinal car sills through the end sill and buffer block or front cross frame pieces of the car, so that the buffing strains may be distributed to the several longitudinal sills and resisted by them all. The stop castings and connecting bolts are shown in red on the attached drawings.

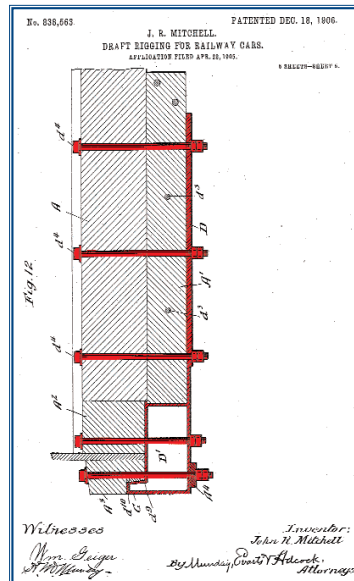
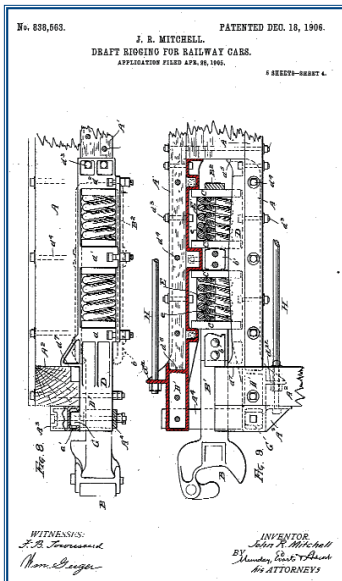
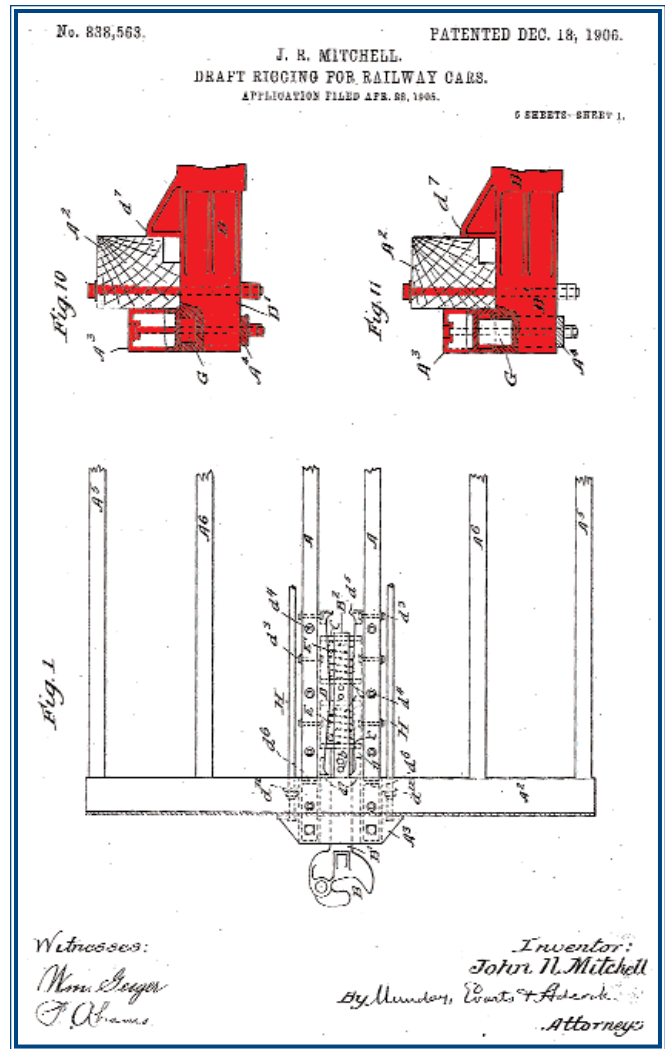



## United States Patent 858,746

**Problem:** Improve stop casting strength.

**Solution:** Design the side plate or stop casting (red) with the necessary stops or shoulders for the followers to abut against. At the same time have a form capable of being so cast as to produce homogenous and perfect castings. A form free from casting strains or other defects incident to unequal distribution of metal and varying thicknesses in different parts of the casting. The stop casting which is of considerable length, also has a straight, flat face to fit against the draft timbers of the sill and to align with all bolt holes and bosses.

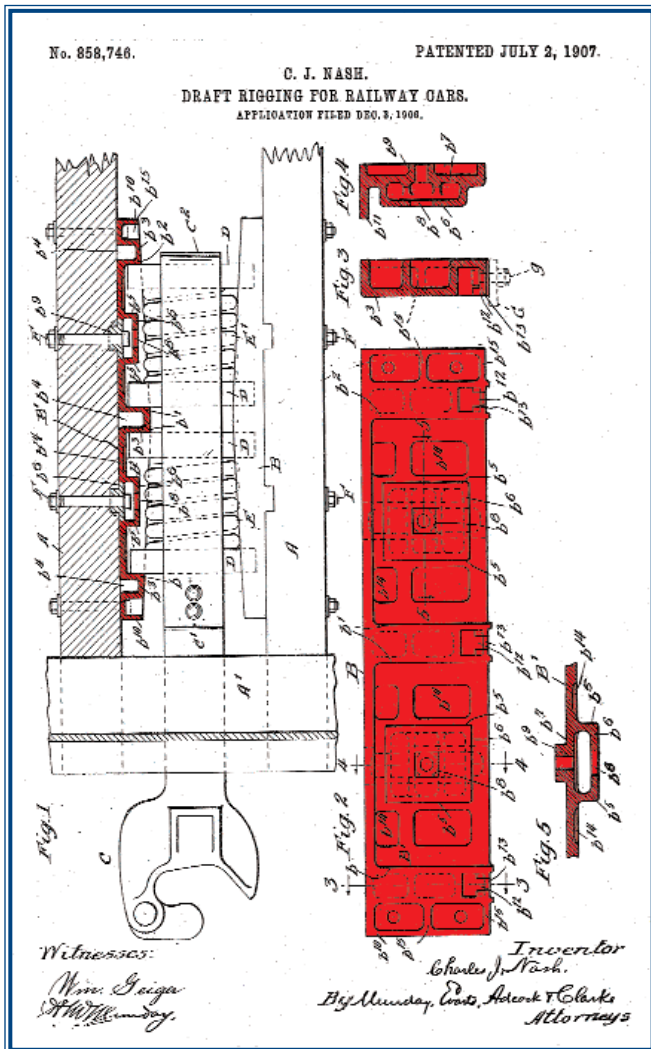

## United States Patent 858,748

**Problem:** Improve construction of side plates or stop castings.

**Solution:** A new procedure to manufacture stop castings (red) without high stress "T" sections.

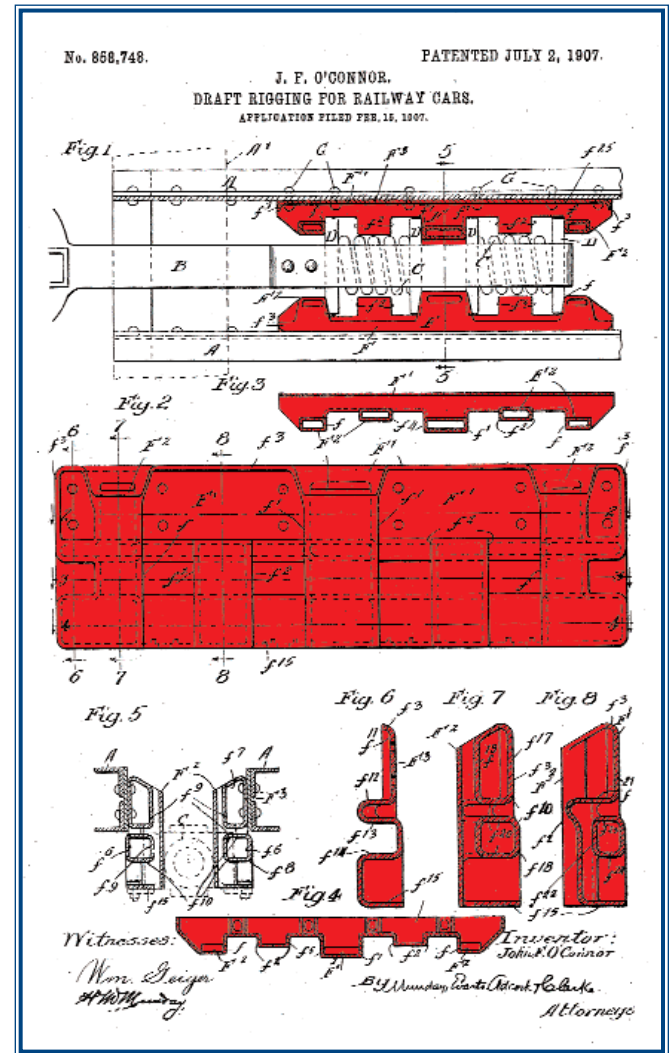

# Railroad Industry Exploded in the Turn of Century

## Bigger Locomotives, Longer Trains, Faster Speeds

The achievement of a truly integrated railroad network resulted in average higher train speeds, which resulted in more mileage utilization of both cars and engines. In addition, operating efficiencies resulted. At the end of the Civil War freight rates declined from over 2 cents a ton mile to about 0.75 cents a ton mile by 1900. Total freight traffic grew from 10,000,000,000 ton-miles in 1865 to 366,000,000,000 ton-miles in 1916.

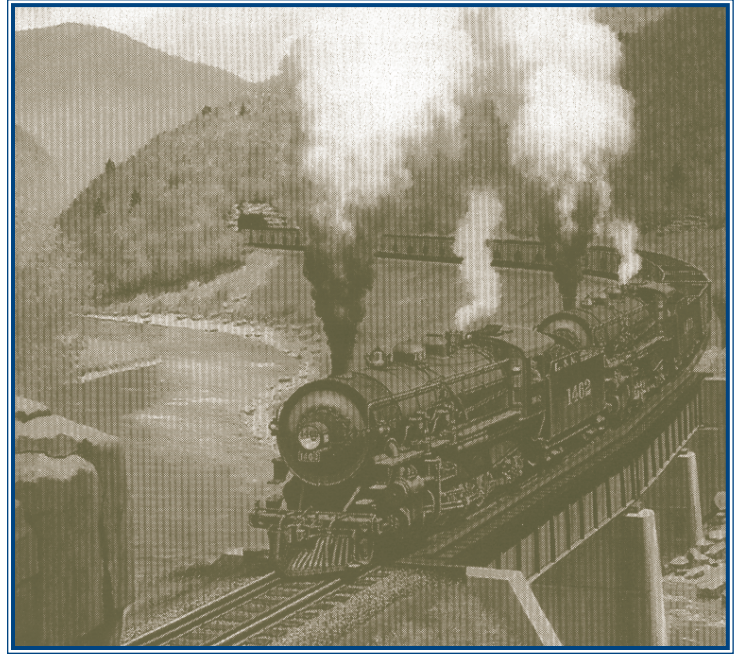

## The Goals:

“Attainment of efficiency and economy”

“Adaptable to any class car”

“Modify without undue expense”

“Return car to service faster”

Miner’s first order opened the opportunity to serve this railroad expansion that went, for example, from an Eastern network of 35,000 miles into a full-grown national system of 254,000 miles. The growth exploded from 164,000 miles in 1890 to 254,000 by 1916.

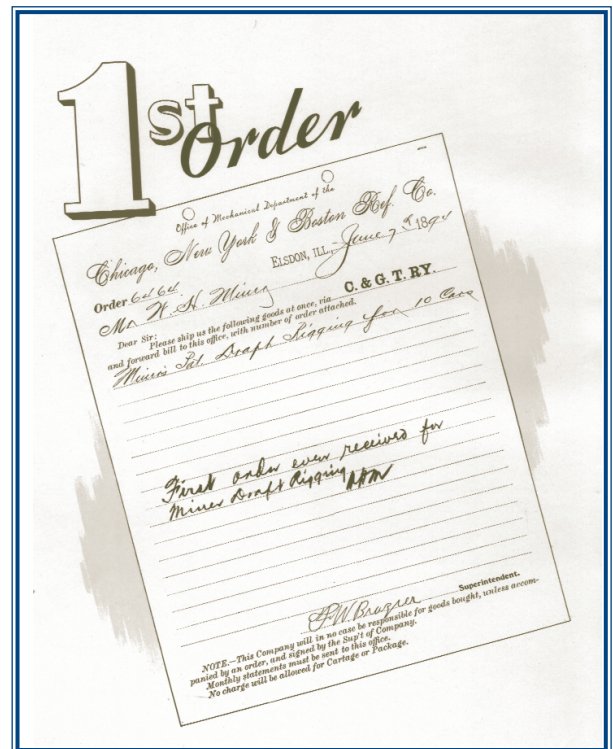



# *Miner Improved Draft Rigging Provides Major Operating Economies*

---



## **Prevents Breakage of Draft Timbers Center Sills Draw Springs Follower Plates Draw Bar Pockets and Coupler**

By the 1890's the majority of car builders preferred short stem coupler arrangements including spring pairs laid out in parallel, piggyback and tandem patterns. As the railroads had increasingly faster speeds, the double stem draft gear never became an industry standard because the connecting draftwood timber had to handle 95.5% of forces involved when the two cars coupled. The forces proved too much for plain timber blocks at higher speeds, and the draft timbers were shattered and torn apart. They looked like "bits of shipwreck washed up on the beach."

Consolidation of railroads and car builders in the decades around 1900 encouraged more uniformity in coupler requirements. Mr. Miner's inventive engineering genius enabled the railroad to meet these new standard goals with considerable savings in wooden car operational costs and extending their in-service use for many years.

## *A Typical Problem*

---

### *Janney's Automatic Coupler*

(Railway Age, Aug. 19, 1887)

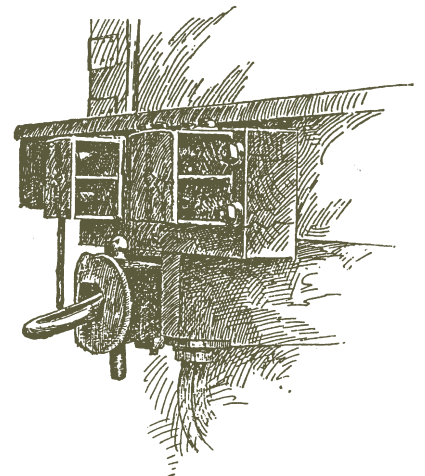
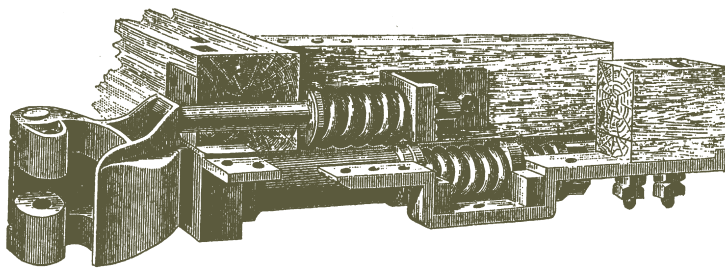

The deadly link-and-pin coupler shown at right was so arranged that the brakeman had to stand between the cars in order to achieve coupling. So hazardous was the job that brakemen were often identified because of missing fingers and/or crushed hands.



# Typical Wooden Freight Cars Built Between 1889-1912 Using Tandem Spring Draft Gears

Box Car, Wooden Underframe.  
Capacity, 60,000 lbs. Weight, 33,600 lbs.  
Length, 34.ft. 4 in. American Car &  
Foundry Co., Builders

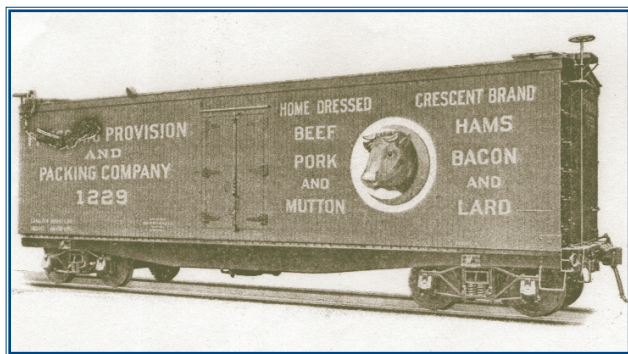
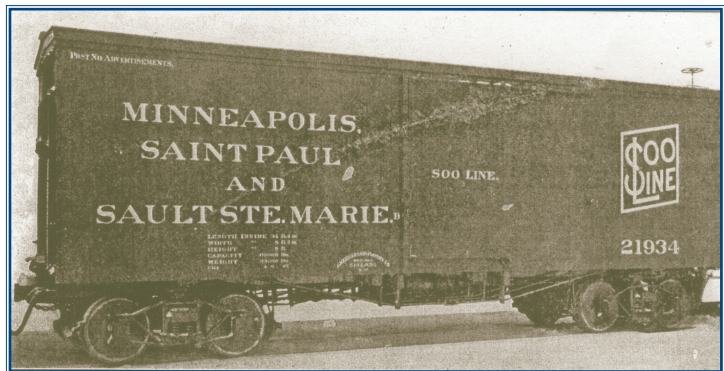

Refrigerator Car, Pressed Steel Underframe.  
Capacity, 50,000 lbs. Weight, 46,100 lbs.  
Length, 35 ft. 2-5/8 in. American Car &  
Foundry Co., Builders

Flat Car, Wooden Underframe.  
Capacity, 80,000 lbs. Weight, 27,200 lbs.  
Length, 41 ft. American Car & Foundry  
Co., Builders



Wooden Refrigerator Car with Collapsible Bulkheads.  
Capacity, 30 Tons; Weight, 52,000 lbs.; Length between  
Bulkheads, 33 ft. 2-1/4 in.; Inside Width, 8 ft. 2-3/4 in.  
Builder, American Car & Foundry Co.

1910 American Car & Foundry Wooden  
Car With Tandem Spring Draft Gears.





# Early Advertising





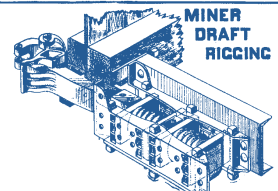
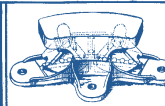

W. H. Miner believed in the power of consistent advertising.

The company supported the publications serving the railway industry from their very beginning and continue to do so in the 21st century.

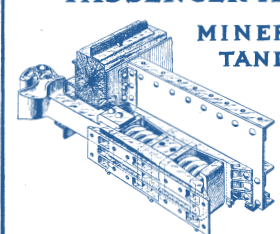
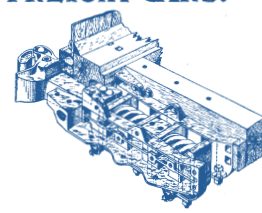
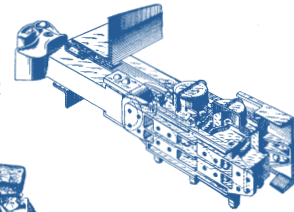
Early advertising showed the expanding line of high quality, tough Miner manufactured railcar components.

<h2 style="margin: 0;">W. H. MINER</h2> <h3 style="margin: 0;">RAILWAY SUPPLIES</h3> <p style="margin: 0;">669 "ROOKERY" CHICAGO</p>		
<p style="font-size: small;">HENNESSEY FRICTION-GEAR.</p>  <p style="font-size: x-small;">PERSPECTIVE VIEW OF GEAR</p>	<p style="font-size: small;">MINER DRAFT RIGGING</p> 	
<p style="font-weight: bold;">BRYAN DRAFT RIGGING</p> <p style="font-size: x-small;">LA-FLARE INSULATION FOR REFRIGERATOR CAR DOORS</p>	 <p style="font-size: x-small;">GRAVITY SIDEBEARING</p>	<p style="font-weight: bold;">HUNT DRAIN CUP</p> <p style="font-size: x-small;">PERFECTION BOLT KEEPER FOR REFRIGERATOR CAR DOORS</p>

Advertising from Car Builders Dictionary/Cyclopedia, 1903

<h2 style="margin: 0;">W.H. MINER CO.</h2> <h3 style="margin: 0;">RAILWAY SUPPLIES</h3>		
<p style="font-weight: bold;">DRAFT RIGGING FOR LOCOMOTIVES, PASSENGER AND FREIGHT CARS.</p>		
 <p style="font-weight: bold;">MINER TANDEM</p>		
<p style="font-weight: bold;">HENNESSEY FRICTION GEAR</p>		
		
<p style="font-weight: bold;">MINER GRAVITY SIDE BEARINGS</p> <p style="font-size: x-small;">FOR ALL CLASSES OF EQUIPMENT</p>		
		
<p style="font-weight: bold;">PERFECTION DOOR BOLT KEEPERS</p>		<p style="font-weight: bold;">LA-FLARE REFRIGERATOR DOOR INSULATION</p>
<p style="font-weight: bold; font-size: large;">"THE ROOKERY" CHICAGO.</p>		

Advertising from Car Builders Dictionary/Cyclopedia, 1906



# *Historical Caboose with Miner Tandem Spring Draft Gear*

---

This Chicago, Burlington & Quincy Railroad Caboose, in the museum at Batavia, IL, includes an original Miner Tandem Spring Draft Gear that was installed in 1907 and still working some 67 years later when the car was retired.

The caboose was built by the CB&Q at their Aurora car shops in May, 1907 at a total cost of \$1,151.37. It was of all wood construction with a truss rod under the frame.

CB&Q Caboose 14662 served as a main line and local caboose until 1970 when it was assigned yard duty in the

Chicago-Eola area. During the 67 years this caboose was in operation, it underwent many modifications and improvements.

This caboose was never renumbered to a BN number following the merger of the Chicago, Burlington & Quincy, Great Northern, Northern and Pacific Coast Railroads in 1970.

What better testimony can there be to the quality and workmanship of Miner products in general and the Miner Tandem Spring Draft Gear in particular!



# *An Evolution of Railcar Draft Gear Protection*

---

In the late 1800s, the American railroad industry was exploding with technical advances in railroad car design and manufacture, and each advance required its own distinct cushioning system. Pockets weren't always the same size or shape, and couplers weren't always in the same spot on the cars. What was needed was one system that could bridge all these gaps.

W. H. Miner's Tandem Spring Draft Rigging was such a system. When customers ordered a Tandem Spring Draft Rigging, what they got was a box of parts that could be assembled to accommodate the car builder's particular needs. With this flexible design, nonstandard wood cars could be satisfactorily cushioned.

Over the years, the Tandem Spring Draft Rigging system evolved from a rather crude device to an extended family of sophisticated units. The basic principles, however, didn't change. The Tandem Spring Draft Rigging system was the premier cushioning system for the railroad industry from 1894 (when Mr. Miner received his first order) until 1916. All together about 4,000,000 Tandem Spring draft gears were sold.

The days of laissez-faire design were passing, however. Standardization was coming and with it a standard pocket and coupler height. By about 1916, the Tandem Spring Draft Rigging had been all but phased out of new car construction. By 1936, a Purdue University publication declared the Tandem Spring Draft Rigging "obsolete."

It was replaced by the friction draft gear – a product that had been around longer than the Tandem Spring Draft Rigging (1887 vs. 1891) but didn't come into its own until certain design and cost problems were resolved. Once they were resolved, however, the Tandem Spring Draft Rigging was left "in the dust." From that day to this, the friction draft gear, with its clearly superior capacity, has been the industry norm.

Today Miner Enterprises, Inc. continues to serve the transportation industry worldwide. We offer quality product engineering and manufacturing innovations that improve operating efficiencies and safety for the economic benefit of our customers.



David W. Withall  
President



W. H. MINER DIVISION  
1200 East State Street, P.O. Box 471, Geneva, IL 60134  
1-630/232-3000 • FAX 1-630/232-3055  
[www.minerent.com](http://www.minerent.com)